



Building Automation

Industrial Automation

Systems

## Hardware and Engineering

# DM4 Soft Starter

08/04 AWB8250-1341GB

All brand and product names are trademarks or registered trademarks of the owner concerned.

1<sup>st</sup> published 1999, edition 08/99

2<sup>nd</sup> published 2001, edition 11/01

3<sup>rd</sup> published 2003, edition 03/03

4<sup>th</sup> published 2004, edition 08/04

See revision protocol in the "About this manual" chapter

© Moeller GmbH, Bonn

Author: Rainer Günzel

Editor: Michael Kämper

Translator: Dominik Kreuzer

All brand and product names are trademarks or registered trademarks of the owner concerned.

All rights reserved, including those of the translation.

No part of this manual may be reproduced in any form (printed, photocopy, microfilm or any other process) or processed, duplicated or distributed by means of electronic systems without written permission of Moeller GmbH, Bonn.

Subject to alterations without notice.



## Warning!

### Dangerous electrical voltage!

---

#### Before commencing the installation

- Disconnect the power supply of the device.
- Ensure that devices cannot be accidentally restarted.
- Verify isolation from the supply.
- Earth and short circuit.
- Cover or enclose neighbouring units that are live.
- Follow the engineering instructions (AWA) of the device concerned.
- Only suitably qualified personnel in accordance with EN 50110-1/-2 (VDE 0105 Part 100) may work on this device/system.
- Before installation and before touching the device ensure that you are free of electrostatic charge.
- The functional earth (FE) must be connected to the protective earth (PE) or to the potential equalisation. The system installer is responsible for implementing this connection.
- Connecting cables and signal lines should be installed so that inductive or capacitive interference does not impair the automation functions.
- Install automation devices and related operating elements in such a way that they are well protected against unintentional operation.
- Suitable safety hardware and software measures should be implemented for the I/O interface so that a line or wire breakage on the signal side does not result in undefined states in the automation devices.
- Ensure a reliable electrical isolation of the low voltage for the 24 volt supply. Only use power supply units complying with IEC 60364-4-41 (VDE 0100 Part 410) or HD 384.4.41 S2.
- Deviations of the mains voltage from the rated value must not exceed the tolerance limits given in the specifications, otherwise this may cause malfunction and dangerous operation.
- Emergency stop devices complying with IEC/EN 60204-1 must be effective in all operating modes of the automation devices. Unlatching the emergency-stop devices must not cause restart.
- Devices that are designed for mounting in housings or control cabinets must only be operated and controlled after they have been installed with the housing closed. Desktop or portable units must only be operated and controlled in enclosed housings.

- Measures should be taken to ensure the proper restart of programs interrupted after a voltage dip or failure. This should not cause dangerous operating states even for a short time. If necessary, emergency-stop devices should be implemented.
- Wherever faults in the automation system may cause damage to persons or property, external measures must be implemented to ensure a safe operating state in the event of a fault or malfunction (for example, by means of separate limit switches, mechanical interlocks etc.).
- According to their degree of protection frequency inverters may feature during operation live, bright metal, or possibly moving, rotating parts or hot surfaces.
- The impermissible removal of the necessary covers, improper installation or incorrect operation of motor or frequency inverter may cause the failure of the device and may lead to serious injury or damage.
- The relevant national regulations apply to all work carried on live frequency inverters.
- The electrical installation must be carried out in accordance with the relevant regulations (e. g. with regard to cable cross sections, fuses, PE).
- All work relating to transport, installation, commissioning and maintenance must only be carried out by qualified personnel. (IEC 60364 and HD 384 and national work safety regulations).
- Installations fitted with frequency inverters must be provided with additional monitoring and protective devices in accordance with the relevant safety regulations etc. Modifications to the frequency inverters using the operating software are permitted.
- All shrouds and doors must be kept closed during operation.
- In order to reduce hazards to persons or equipment, the user must include in the machine design measures that restrict the consequences of a malfunction or failure of the drive (increased motor speed or sudden standstill of motor). These measures include:
  - Other independent devices for monitoring safety-related variables (speed, travel, end positions etc.).
  - Electrical or non-electrical system related measures (interlocks or mechanical interlocks).
  - Live parts or cable connections of the frequency inverter must not be touched after it has been disconnected from the power supply due to the charge in capacitors. Appropriate warning signs must be provided.

## Contents

	<b>About This Manual</b>	5
	List of revisions	5
	Abbreviations and symbols	6
<hr/>		
<b>1</b>	<b>About the Series</b>	7
	System overview	7
	– Soft starter features	9
	Selection criteria	10
	– Parallel connection of several motors to one soft starter	10
	– Connecting motors during soft starter operation	10
	– Connectable motor rating	10
	– Power dissipation $P_V$	13
	– Permissible environmental influences	14
	Intended use	15
	Storage, transportation, disposal	17
<hr/>		
<b>2</b>	<b>Engineering</b>	19
	Device selection	19
	EMC compliance	20
	Mains configurations	20
	Cable connection (electrical connection)	20
	– P. f. correction systems	23
	– Protective elements	24
	– UL-compliant configuration	24
	– Cables, contactors, mains filters	27
	Connecting motors	28
	– Long motor cables	30
	Connection types	31
	– General Enable/instant stop without ramp function (e. g. on EMERGENCY STOP)	31
	– Inclusion of the overload relay in th control system	32
	– Ready for operation signal	35
	– Standard connection	36
	– Bypass connection	40

– Pump connection	44
– In-delta connection	48
– Reversing circuit	52
– Starting several motors in succession with a soft starter	54
– Connecting motors to a soft starter in parallel	58
Connecting the controller	59
– Controller supply voltage (rated control supply voltage $U_c$ )	59
– Internal voltages	61
– Earthing the zero potential (terminal 39)	62
– Digital inputs, PLC interconnection	64
– Inputs for analog setpoint values	66
– Reference input value definition with current signal	67
– Analog outputs	67
– Relay contacts	68
<hr/>	
<b>3 Defining Parameters</b>	<b>71</b>
Principles of operation	71
– Display of special characters on the LCD keypad	72
– Application selector switch	72
Default settings of the basic unit	75
Basic settings	76
Configuring the basic unit	79
– Control (submenu)	79
– Misc (submenu)	90
Open and closed-loop control functions	92
– Kickstart (submenu)	96
– Current (submenu)	96
– cos-phi (p. f.) optimization (submenu)	100
– Terminal configuration	102
– Digital-In (submenu)	103
– Analog-In (submenu)	104
– Command (submenu)	105
– PhaseControl (submenu)	108
Display functions	110
– Device Data (submenu)	110
– Status (submenu)	110
– Display (submenu)	113

– Analog-Out (submenu)	114
Monitoring functions	117
– Relay output K1 (submenu)	118
– Relay outputs K2 to K4 (submenus)	124
– Heatsink (submenu)	125
– Thermistor (submenu)	126
– Motorprotect (submenu)	128
Viewing fault messages	131
– Fault codes	132
– Reset fault message/register	133
Parameters not in the menu structure	133
– Network operation (from software version PNU 99 = 53.12)	133
– Parameter data channel	134
– Process data channel	134
<hr/>	
<b>4 Mounting/Installation</b>	<b>137</b>
Scope of delivery	137
Installing in a control cabinet	137
– Possible mounting positions	141
– Connections	143
– Connecting the motor cable	144
– Screening the motor cables	145
– Connecting the control signal cables	145
– Screening the control signal cables	146
<hr/>	
<b>5 Operation</b>	<b>147</b>
Start-up	147
Switching on	148
Starting the motor	149
Operation	149
Stopping	151

<b>6</b>	<b>Diagnostics</b>	153
	Troubleshooting	153
	Fault messages and remedy	154
	– Fault reset	155
	– LED displays	155
	Monitoring signals	156
	– Fault messages on Power On	156
	– Fault messages during operation	157
<b>7</b>	<b>Menu Structure/Operating Software</b>	159
	Menu structure	159
	Special features of the LCD keypad	168
	<b>Appendix</b>	169
	Standards	169
	Technical data	170
	Control inputs/outputs	190
	Overload withstand capability	192
	– Conversion of overload withstand capability to lower overcurrents	193
	Parameters/equipment	194
	Parameter types	195
	Parameter table (PNU)	196
	Parameter table (alphabetic)	198
	External add-on components	226
	– Contactor and motor protection devices	226
	Dimensions	236
	<b>Index</b>	241

## About This Manual

This manual contains the information you need to connect the soft starter correctly and to configure the drive parameters to your requirements.

The information in this manual applies to the software from version 52.09 or later and to the specified hardware.

The manual covers all models of the soft starter range. Specific references are made to differences and special features of individual variants.

### List of revisions

Published on	Page	Keywords	New	Changed	Omitted
11/01	General	Complete revision and new functions from software version PNU 99 = 53.12	✓		
03/03	23	P. f. correction systems	✓		
	35	Ready for operation signal	✓		
	40	Note about "K1-delaytime"	✓		
	49	Note about completion of stopramp	✓		
	50	Figure 21		✓	
	62	Inputs E1 and E2 with +12 V		✓	
	122	Note about "K1-delaytime"	✓		
	146	Note about extreme EM interference	✓		
08/04	38, 42, 46, 50, 52, 55	Figures		✓	
	125	Last paragraph	✓		

## Abbreviations and symbols

The following abbreviations and symbols are used in the manual:

PNU: **Parameter number**

DEF: **Default setting**

► Indicates actions to be taken.



Provides useful tips and additional information.



### **Caution!**

Indicates risk of light material damage.



### **Warning!**

Indicates risk of serious material damage and slight injury.



### **Warning!**

Indicates risk of serious material damage and serious or fatal injury.

# 1 About the Series

## System overview

The soft starters have the following type code, which provides the following information:

### **DM4-xxx-yy**

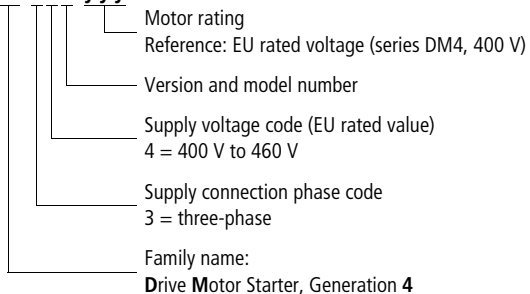

Figure 1: Structure of type code

The following example shows the type code for a typical frequency inverter.

### **DM4 - 3 40 - 22 K**

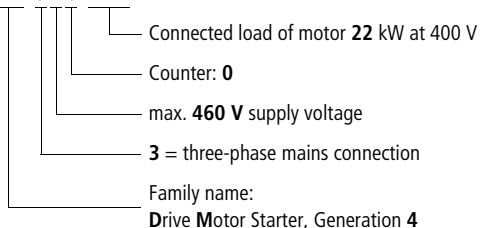

Figure 2: Sample type code

The DM4 soft starters regulate the supply network voltage between an adjustable starting value and 100 %. If a three-phase asynchronous motor is operated with this supply network, its starting torque is significantly reduced. This ensures that three-phase induction motors start up smoothly at a reduced starting current.

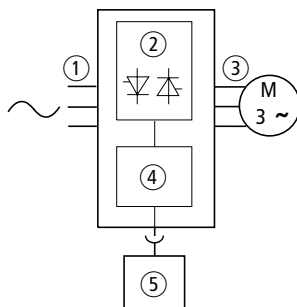

Figure 3: Function chart

- ① Mains voltage ( $U_{1N}$ ):  $3 \times 230 \text{ V}$  to  $3 \times 460 \text{ V}$
- ② Anti-parallel thyristors in all three phases control the motor voltage
- ③ Output voltage ( $U_2$ ):  
three-phase, ramped from an adjustable starting voltage up to 100 % mains voltage at constant mains frequency.  
Output current ( $I_{2N}$ ):  
15 A to 900 A at a maximum ambient temperature of 40 °C.  
Motor shaft output ( $P_2$ ):  
7.5 to 500 kW at 400 V with standard connection  
or 10 to 750 HP at 460 V  
11 to 900 kW at 400 V with in-delta connection  
or 15 to 1300 HP at 460 V
- ④ Controller card: controls the power section. Control commands are processed here and parameters defined.
- ⑤ With the plug-in LCD keypad, parameters can be changed or viewed as plain text.

### Soft starter features

Compact construction	✓
Current limit reaction	✓
Adjustable starting voltage	✓
Adjustable breakaway torque (kick)	✓
Separately adjustable ramp times for startup and stop	✓
Adjustable current limitation	1- to 8-fold
Energy saving function (p. f. control)	✓
Pre-programmed, application-dependent parameter sets	✓
Configurable digital inputs	2
Configurable analog inputs/outputs	2/2
Configurable relay outputs	4
Can be used as soft starter and generalized phase control	✓
Standardized controller card and parameters across the whole power range	✓
Networkable	Optional
Serial interface	Optional
LCD keypad	Optional
Fault memory	5 messages
Two parameter sets	✓
In-line (default) or in-delta control (reduction of phase current by $1/\sqrt{3}$ )	✓

---

**Selection criteria**

Select the soft starter according to the motor's rated current and the type of load. The load must have a quadratic speed/torque characteristic. Loads with linear or constant speed/torque characteristics cannot be started at full load with the soft starter (e. g. piston pumps can be run up only with bypass valves).

The rated output current of the soft starter must be the same as or greater than the rated motor current. For motors with a high starting resistance, the selected starter must be dimensioned accordingly to avoid overloads.

**Parallel connection of several motors to one soft starter**

Select the soft starter according to the sum of the rated currents of all motors.

**Connecting motors during soft starter operation**

No soft start is performed in this case. The starter must be able to supply the full starting current (approx. 6 to 8 times rated motor current) and the current for the remaining motors. Otherwise an overcurrent trip is triggered.

**Connectable motor rating**

With standard motors and normal loads suitable for soft starters, motors with the following ratings can be connected.

**Standard connection**

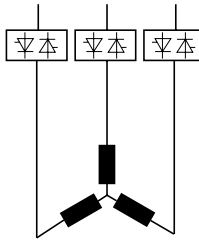

Figure 4: Standard connection method

DM4-340-...	Motor rating		
	in kW at 230 V	in kW at 400 V	in HP at 460 V
...-7K5	3	7.5	10
...-11K	5.5	11	15
...-15K	7.5	15	20
...-22K	11	22	30
...-30K	15	30	40
...-37K	18.5	37	50
...-45K	22	45	60
...-55K	30	55	75
...-75K	37	75	100
...-90K	45	90	125
...-110K	55	110	150
...-132K	75	132	200
...-160K	90	160	250
...-200K	110	200	300
...-250K	132	250	400
...-315K	160	315	500
...-400K	200	400	600
...-500K	250	500	750

### In-delta connection

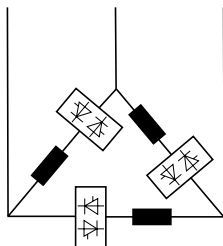

Figure 5: In-Delta connection

DM4-340-...	Motor rating		
	in kW at 230 V	in kW at 400 V	in HP at 460 V
...-7K5	7.5	11	15
...-11K	11	15	20
...-15K	15	22	30
...-22K	22	37	50
...-30K	30	55	75
...-37K	37	55	75
...-45K	45	75	100
...-55K	55	90	125
...-75K	75	132	200
...-90K	90	160	250
...-110K	110	160	250
...-132K	132	200	300
...-160K	160	250	400
...-200K	200	315	500
...-250K	250	400	600
...-315K	315	560	850
...-400K	400	750	1100
...-500K	500	900	1300

### Power dissipation $P_V$

The soft starter's power dissipation  $P_V$  depends on the operating condition of the connected motor. The values listed below apply to rated operation of the motor parameters (rated motor output, 4-pole three-phase induction motor) at an ambient temperature of 40 °C.

At startup, the current exceeds the rated current. All types of enclosures in which the starter is to be installed must allow discharge of the dissipated power. Depending on the ramp time and current limit settings, this current can flow for several seconds. Any power dissipation must be accounted for in the enclosure layout.

DM4-340-...	Controller supply [W]	Power section				
		$1 \times I_e$ [W]	$2 \times I_e$ [W]	$3 \times I_e$ [W]	$4 \times I_e$ [W]	$5 \times I_e$ [W]
...-7K5	5	45	107	186	282	395
...-11K	5	58	132	221	325	445
...-15K	8	83	195	335	504	702
...-22K	8	109	246	411	603	824
...-30K	11	141	325	553	824	1139
...-37K	11	179	404	677	996	1361
...-45K	11	216	497	844	1255	1731
...-55K	11	265	606	1023	1516	2085
...-75K	11	370	875	1516	2292	3203
...-90K	14	438	1019	1742	2607	3614
...-110K	14	531	1258	2182	3303	4621
...-130K	14	648	1556	2722	4148	5833

## About the Series

DM4-340-...	Controller supply [W]	Power section				
		$1 \times I_e$ [W]	$2 \times I_e$ [W]	$3 \times I_e$ [W]	$4 \times I_e$ [W]	$5 \times I_e$ [W]
...-160K	14	781	1916	3403	5242	7435
...-200K	14	911	2130	3658	5494	7640
...-250K	125	1246	2917	5013	7534	10481
...-320K	125	1580	3796	6647	10133	14254
...-400K	125	1981	4520	7618	11275	15490
...-500K	125	2649	6222	10719	16138	22481

**Permissible environmental influences**

Degree of protection:  
IP20

Altitude:  
Up to 1000 m above seal level; above this up, to 2000 m with a current drop of 1 % per 100 m additional height.

Temperature:

Operation 0 to 40 °C without reduction, up to 50 °C with a reduction of 2 % per °C

Storage -25 to +55 °C constant, -25 to +75 °C max. 24 hours

Transport as for storage

Climatic proofing:

Damp heat, cyclic, to IEC 60068-2-30

Damp heat, constant, to IEC 60068-2-3

**Intended use**

DM4 soft starters are electrical apparatus for installation in control cabinets of electrical systems or machines.

The DM4 series devices are intended for use as components for the smooth control of three-phase induction motors (squirrel cage motors). They are designed for installation in machines or for use in combination with other components forming a machine or system.

During installation of the machine, do not take the soft starters into operation before you have made sure that the assigned machine meets the safety requirements of Machinery Safety Directive 89/392/EEC. The standard EN 60204 must also be observed.

Commissioning is allowed only when the EMC Directive (89/336/EEC) has been fulfilled.

The soft starters fulfil the requirements of the Low Voltage Directive 73/23/EEC.

The soft starters fulfil Product Standard EN 60947-4-2.

The soft starter's output (terminals 2T1, 4T2, 6T3) must not be used to

- connect a capacitive load (such as p. f. compensation capacitors),
- connect multiple soft starters with each other.

Observe the technical data and terminal requirements. Refer to the equipment nameplate or label and the documentation for more details.

The DM4 series devices

- are suitable for use in public and non-public networks (for restrictions see section “EMC compliance” on page 20);
- are not household devices but are components solely intended for use in commercial applications;
- are not machines as covered by the EU Machine Directive;
- can be used in an industrial environment and in a domestic and business environment with the system configurations described in this manual;
- in typical drive configurations, comply with the EU EMC Directive, the EU Low-Voltage Directive and the stated standards.

The user of the equipment is responsible for ensuring that the machine application complies with the relevant EU Directives.

Any other usage constitutes improper use.

---

**Storage, transportation,  
disposal**

DM4 soft starters are carefully packaged and prepared for shipment. The device may be transported only in its original packaging with a suitable transportation system (see weight details in section "Dimensions" from page 236). Observe the labels and instructions on the packaging. This applies also to the unpacked equipment.

After receiving the delivery,

- check for external damage of the packaging;
- confirm that the details on the delivery note match your original order.

Open the packaging with suitable tools and check whether:

- any parts have been damaged during transportation;
- the equipment corresponds with the model that you ordered;
- the installation instructions are enclosed.

In case of damage, incomplete or incorrect shipment, please notify the responsible sales office.

According to the currently applicable national regulations, DM4 series soft starters can be recycled as electronic scrap.



## 2 Engineering

---

### Device selection

For standard applications with standard asynchronous motors, soft starters can be dimensioned according to the rated motor output using the information provided in the technical data (see appendix).

For drives with a high starting torque or high mass inertia, more precise dimensioning is required. To select a device, the machine's overload cycle must be known:

- Starting time for d.o.l. start or star/delta start
- Max. starting current
- Load cycle
- The load to be driven by the motor

For precise dimensioning, the mass inertia moments and the speed/torque characteristics of motor and load must also be known. With these values, the appropriate soft starter can be selected. The procedure to be used is described in manual "Soft Starter Design" (AWB8250-1346GB) and applies to all Moeller soft starters. The required key data for the DM4 series (rated current, overload capability, r.m.s. current at rated operating frequency), which is also needed for dimensioning, is listed in the technical data (see appendix).

---

**EMC compliance**

EMC = **E**lectromagnetic **C**ompatibility.

The standard EN 60947-4-2 refers to the limit classes described in EN 55011.

No additional measures are required to limit transmission of radio interference to EN 55011 Class A (industrial environments). For Class B, a bypass contactor must be used. Use a bypass contactor according to AC-1 (see bypass contactor recommendations in the appendix).

---

**Mains configurations**

In the following system configurations, DM4 series soft starters can be used without restrictions:

- with grounded and ungrounded star point
- with isolated star point (IT networks)
- with grounded phase conductor

---

**Cable connection  
(electrical connection)**

Legend for figure 6:

- ① Line protection
- ② Mains contactor
- ③ Semiconductor fuse
- ④ Controller supply line protection
- ⑤ Soft starter
- ⑥ Motor

Cable connection  
(electrical connection)

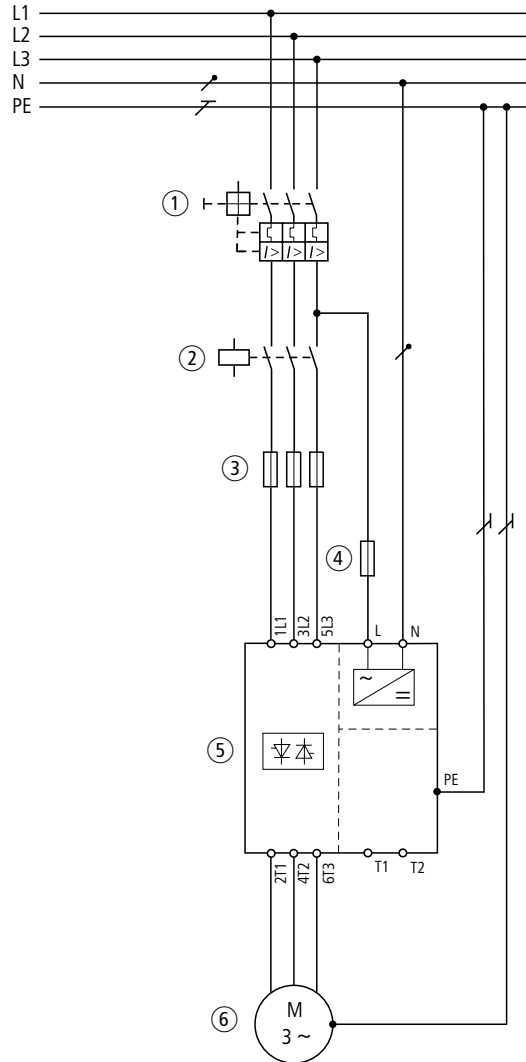

Figure 6: Connection of power lines

T1: +Thermistor

T2: -Thermistor

The soft starter's output (terminals 2T1, 4T2, 6T3) must not be used to

- connect a capacitive load (such as phase compensation capacitors),
- connect several soft starters in parallel,
- supply mains voltage,

Protective elements for the power section should be dimensioned according to the mains network configuration being used.

Line and device protection on the supply side:

- Input AC..., through commercially available fuses for line protection or motor-protective circuit-breaker
- Fuses for UL compliant systems must have UL approval
- Fuses must be chosen with rated voltages suitable for the mains voltage at the installation site.

On the motor side, no fuses are required.

**P. f. correction systems**

If the network with the DM4 soft starter also contains p. f. correction systems, chokes must also be fitted. Otherwise, faults may occur in the DM4 when the p. f. correction system operates (Fig. 7: L1).

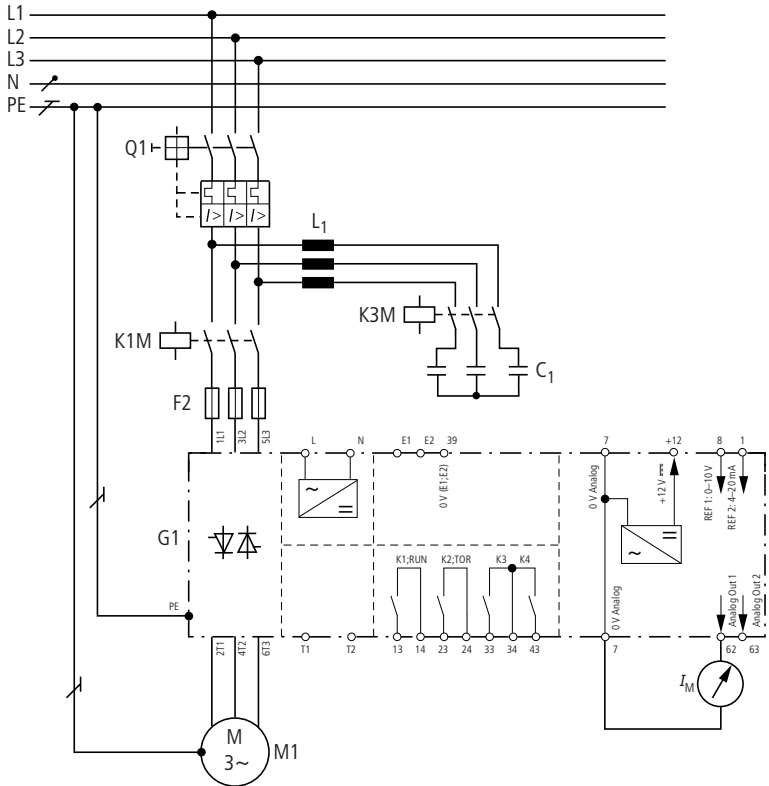

Figure 7: DM4 with p. f. correction

$I_M$ : Motor current

T1: +Thermistor

T2: -Thermistor

E1: Start/Stop

E2: Enable

### Protective elements

Protect the devices with the protective elements listed in the external auxiliary components table (see section "External auxiliary components" in the appendix). Depending on the coordination type required, different protective elements must be used.

Type "1" coordination:

The specified circuit-breakers protect the line and the motor. Short-circuits can damage the soft starter.

Type "2" coordination:

In addition to the protective devices for type "1" coordination, superfast semiconductor fuses are required, which protect the soft starter from damage in the event of a short-circuit. The semiconductor fuses do not have line protection functions.

For soft starters up to 146 A (up to including DM4-340-75K), fit the semiconductor fuses externally; on larger soft starters, you can fit them inside the device. To do this, remove the metal jumpers fitted as standard. The appropriate fuse types are listed in section "External auxiliary components" in the appendix.

### UL-compliant configuration

To ensure UL-compliance, use the following fuses. The details apply to the maximum short-circuit currents listed in the table.

An internal installation of the fuses in the devices  $\geq 90$  kW is not permissible for UL-compliance.

DM4-340-...	Bussmann International Inc. $I_{qu} = 300 \text{ kA}$ Type	Ferraz $I_{qu} = 200 \text{ kA}$ Type	Fuse rated current	Max. short-circuit current $I_q$
...-7K5	–	–	40 A	5000
	170M3110	6.6 URD 30 D08 A 0063	63 A	
...-11K, ...-15K	–	–	80 A	5000
	170M3112	6.6 URD 30 D08 A 0100	100 A	
...-22K	–	–	125 A	5000
	170M3114	6.6 URD 30 D08 A 0160	160 A	
...-30K	–	–	125 A	5000
	170M3115	6.6 URD 30 D08 A 0200	200 A	
...-37K, ...-45K	–	–	200 A	10000
	170M3116	6.6 URD 30 D08 A 0250	250 A	
...-55K, ...-75K	–	–	350 A	10000
	170M3119	6.6 URD 30 D08 A 0400	400 A	
...-90K, ...-110K	–	–	450 A	10000
	170M3121	6.6 URD 30 D08 A 0500	500 A	

DM4-340-...	Bussmann International Inc. $I_{qu} = 300 \text{ kA}$ Type	Ferraz $I_{qu} = 200 \text{ kA}$ Type	Fuse rated current	Max. short-circuit current $I_q$
...-132K	170M4114	6.6 URD 31 D08 A 0500	500 A	10000
...-160K	170M4114	6.6 URD 31 D08 A 0500	500 A	18000
...-200K	170M4116	6.6 URD 31 D08 A 0630	630 A	18000
...-250K	170M6113	6.6 URD 33 D08 A 0900	900 A	18000
...-315K	170M6113	6.6 URD 33 D08 A 0900	900 A	30000
...-400K	170M6116	6.6 URD 33 D08 A 1250	1250 A	30000
...-500K	170M6116	6.6 URD 33 D08 A 1250	1250 A	42000

### **Cables, contactors, mains filters**

The cable types used must comply with the regulations applicable at the installation site.

If frequent startups and high starting currents are likely, larger capacity lines and contactors may have to be used. The contactors' load capacities are listed in their documentation. The correct assignment of mains contactors for selected start cycles to the soft starters is given in section "External auxiliary components" in the appendix.



Always connect the soft starter with the earth-current circuit through the designated PE terminals and through the enclosure. Always observe the minimum cross-section of PE cables specified in the relevant standards and directives (EN 50178, VDE 0160). The cross-section of the PE conductor must be at least as large as that of the power cables ( $\geq 10 \text{ mm}^2$ , AWG 8).

For information about the correct fuses and cable cross sections for incoming and outgoing cables, see heading "External auxiliary components" in the appendix.

The information in the appendix applies to:

- installation in control cabinets and machines,
- installation in cable ducts,
- the max. ambient temperature of +40 °C,
- the normal start frequency.

The fuses and cable cross-sections depend on the soft starter's performance characteristics and the start cycles (operating frequency, overcurrent).



When choosing cable cross-sections, allow for the voltage drop at load application. The user is responsible for ensuring conformance with any other applicable standards.

---

### Connecting motors

Although the DM4 series soft starters are designed for use with three-phase induction motors, they can also be used with the following motor types:

- Pole-changing three-phase motors (Dahlander)
- Rotor three-phase motors (slipping inductors)

The DM4 can be used with these motor types only if the application (i. e. the machine) allows it and this combination has been approved by the motor manufacturer. With pole-changing motors, you must disable the soft starter before changing over the windings.

The soft starter's output voltage determines the motor torque. You should therefore ensure a sufficiently high starting voltage to prevent overheating of the motor before it starts up.

You can operate three-phase motors with different circuit configurations. The circuit configuration depends on the rated power of the motor.



With mains supplies of  $3 \times 400\text{ V}$ , motors are typically connected as follows:

- up to approx. 4 kW in a star connection (230/400 V)
- above 4 kW in delta connection (400/690 V)

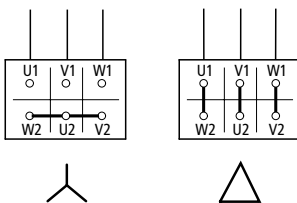

Figure 8: Circuit configurations

Standard connection produces a clockwise rotating field. Interconnect the motor and the soft starter as follows to ensure that the motor turns in a clockwise direction:

Mains	DM4	Motor
	Input	
L1	1L1	U1
L2	3L2	V1
L3	5L3	W1

The direction of rotation of the motor can be reversed in a number of ways by reversing two phases on the motor:

- Changing the connection permanently
- Using a reversing contactor combination
- Using an electronic reversing contactor



Before reversing the rotation, disable the soft starter's output.



Full motor protection to VDE standards is achieved by using overcurrent relays and temperature monitoring. PTC thermistors or temperature switches with PTC characteristics are best suited for monitoring the motor temperature.

### **Long motor cables**

The motor cables should not be longer than 100 m, as the capacitance and inductance of cabling could otherwise result in soft starter malfunction. If necessary, it may be possible to use a longer cable by fitting an inductive base load directly at the soft starter's output.

---

**Connection types****General Enable/instant stop without ramp function  
(e. g. on EMERGENCY STOP)**

By default, digital input E2 is programmed to issue the Enable signal. The soft starter is enabled only when a High signal is applied to the terminal. Without the Enable signal, the soft starter cannot be operated.

In the event of an open circuit or a signal interruption by the EMERGENCY STOP circuit, the soft starter's controller is immediately disabled and the power circuit is disconnected before the Run relay drops out.

Normally, the drive is always stopped with a ramp function. If operating conditions require immediate voltage isolation, this is done with the Enable signal.

**Warning!**

Always stop the soft starter (scan the Run relay) before you mechanically disconnect the power lines. Otherwise the flowing current is interrupted, resulting in voltage peaks, which may destroy the soft starter's thyristors.

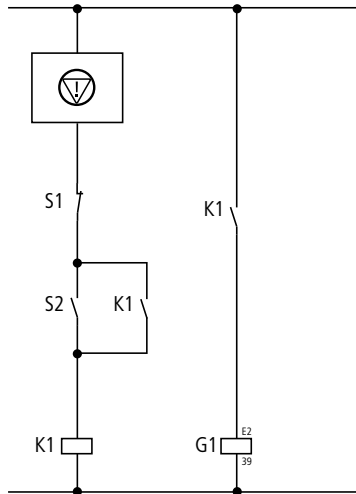

Figure 9: DM4-340 EMERGENCY STOP immediate stop

⊘ : EMERGENCY STOP

S1: Off

S2: On

G1: Enable: (E2 = 1 → enables)

### Inclusion of the overload relay in the control system

Instead of a motor-protective circuit-breaker with built-in motor-protective relay, we recommend the use of an external motor-protective relay. Otherwise you can not ensure that the soft starter is brought to a controlled halt in the event of an overload.



#### Warning!

When the power lines are opened directly, overvoltages may occur, which can destroy the semiconductors in the soft starter.

There are three possibilities of protecting against this, which are shown in the illustration below:

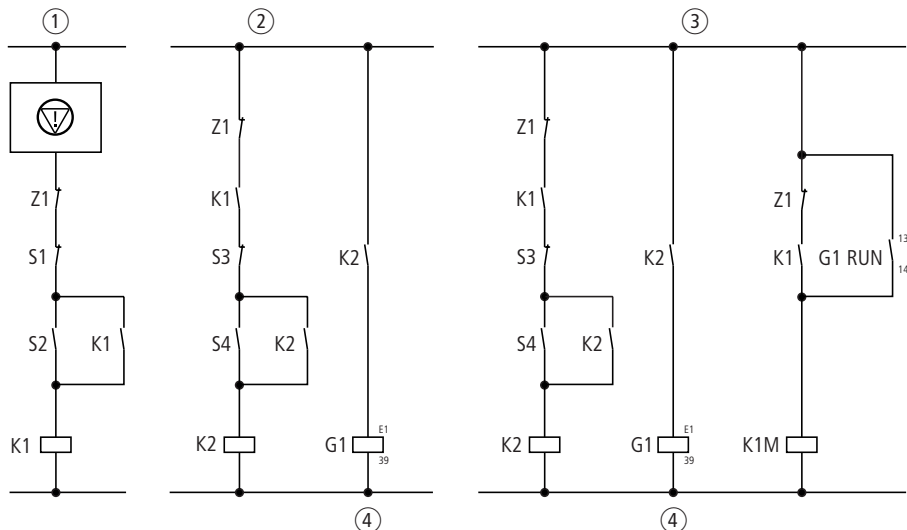

Figure 10: DM4 with Z relay, control circuit

- ① The signal contacts of the overload relay are incorporated in the On/Off circuit. In the event of a fault, the soft starter is disabled immediately and the motor coasts to a halt. Mains contactor K1M drops out as soon as the Run relay drops out.
- ② The signal contacts of the overload relay are incorporated in the soft start/stop circuit. When a fault occurs, the soft starter is ramped down. Although the soft starter shuts down, the mains contactor remains switched on.
- ③ To switch the mains contactor off as well, incorporate a second contact of the overload relay in the branch of mains contactor K1M in addition to version ②. When the soft stop is completed, the run relay drops out, thereby opening the holding circuit of K1M.
- ④ Soft start, Soft stop
- ⊖: EMERGENCY STOP
- S1: Off
- S2: On
- S3: Soft stop
- S4: Soft start

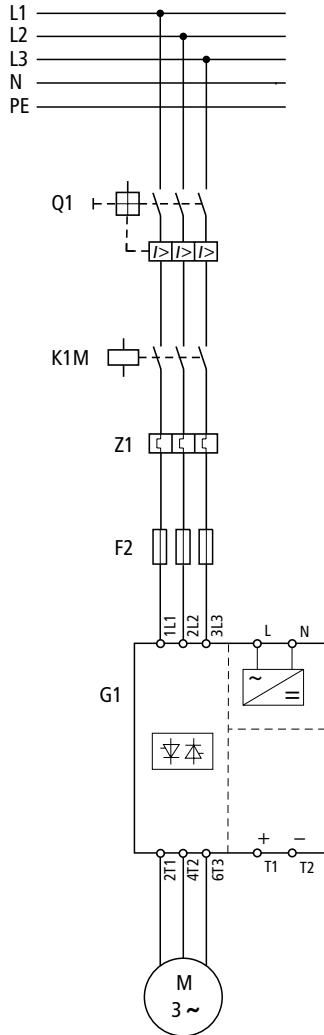

Figure 11: DM4 with Z relay

T1: +Thermistor

T2: -Thermistor

### Ready for operation signal



Figure 12: DM4 ready for operation  
EMERGENCY STOP circuit

To prevent the mains contactor switching on when the DM4 has detected an internal fault, you can connect relay K3 (terminal 33/34) of the DM4 in series with the EMERGENCY STOP circuit (Fig. 12). Set the relay logic of K3 to PNU 651 = 0 (Low signal causes switching). The relay then supplies operational readiness of the DM4 instead of a general fault message. The power supply of the DM4 must separate from the supply of the motor. To change PNU 651, use the external DE4-KEY-2 keypad or the DE4-CFG-200 operating software with the DE4-COM-2X interface module. These are not part of the standard soft starter package content.

### Standard connection

In normal operation, the soft starter is connected into the motor supply line. To isolate it from the mains, a mains contactor before the soft starter or a central switching element (contactor or master switch) is required. The illustrations below show examples of both options.

To achieve radio interference level B, a bypass contactor must be fitted.

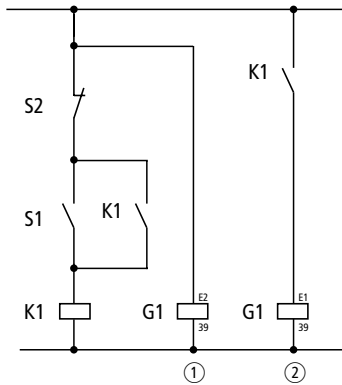

Figure 13: Control circuit, DM4-340 without separate mains contactor

- ① Enable
- ② Soft start, Soft stop
- S1: Soft start
- S2: Soft stop

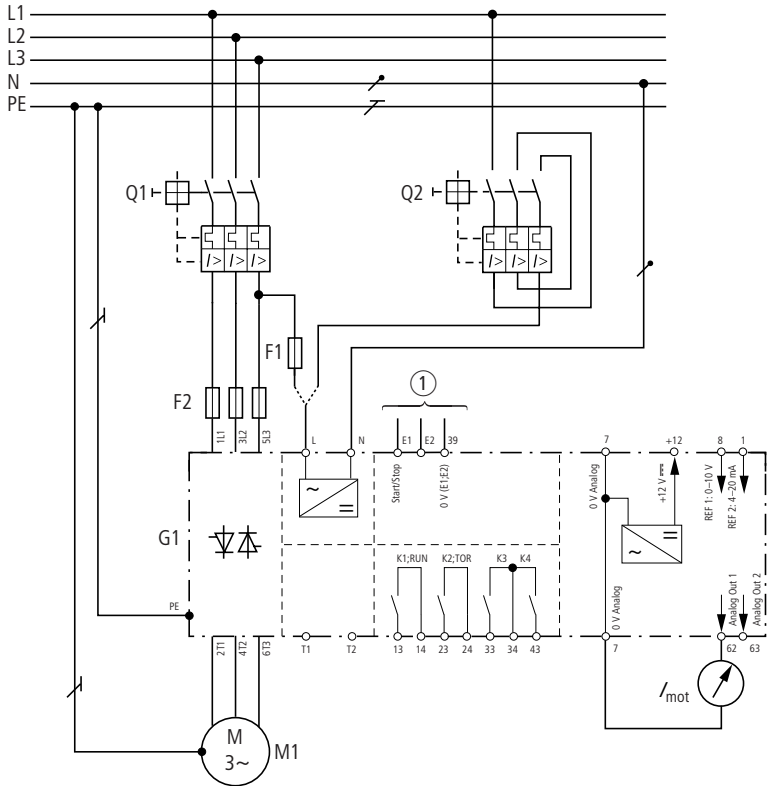

Figure 14: DM4-340 without separate mains contactor

① See actuation

E2: Enable

T1: +Thermistor

T2: -Thermistor

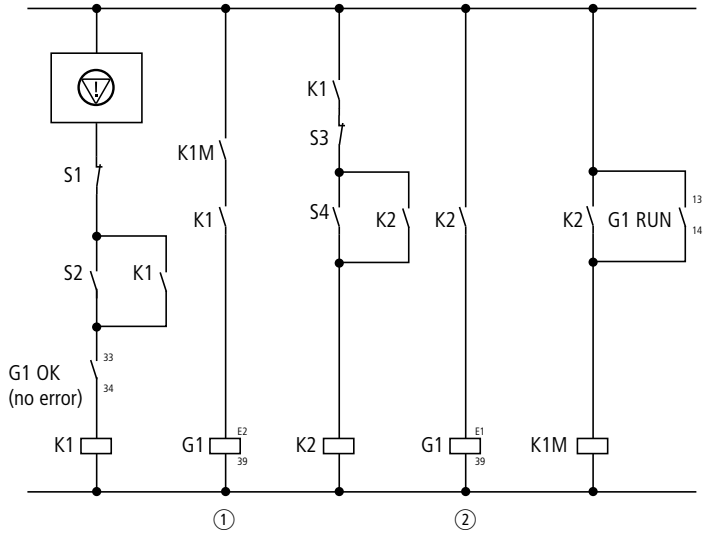

Figure 15: Control circuit, DM4-340 with separate mains contactor

- ① Enable
- ② Soft start, Soft stop
- ⊕:EMERGENCY STOP
- S1: Off
- S2: On
- S3: Soft stop
- S4: Soft start

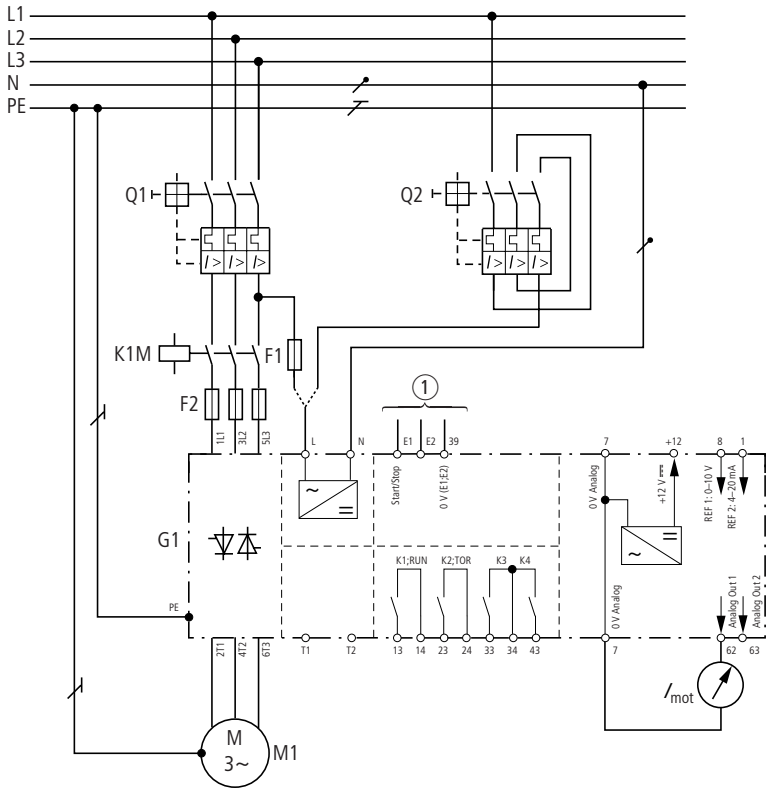

Figure 16: DM4-340 with separate mains contactor

- ① See actuation
- E2: Enable
- T1: +Thermistor
- T2: -Thermistor

### Bypass connection

With the bypass connection, the motor can be connected directly to the mains, thereby suppressing power dissipation through the soft starter. After completion of the startup, the soft starter controls the bypass contactor (full mains voltage reached). The Top of Ramp function is by default assigned to relay K2, so that the bypass contactor is controlled by the soft starter. No further user input is required. Because the bypass contactor does not have to switch the motor load, being switched only at zero current, it can be dimensioned to AC-1. Suitable bypass contactors are listed in the technical data (see appendix).



In bypass operation, make sure that you set the protective function of the soft starter to Phase Failure Only or Start+Bypass, otherwise power factor (p. f.) optimization is active, resulting in soft starter malfunction. Parameter PNU 655 AutoBypass is factory set to 1. With this setting, the DM4 automatically recognizes a connected bypass and switches the protection function to Start+Bypass. No further user actions are then necessary.



In configurations with several switching elements between TOR relay and bypass contactor, you have to match parameter K1-delaytime (PNU 71) for large switching times (> 160 ms) (see section "Relay output K1 (submenu)", page 118).

If, in an EMERGENCY STOP, an immediate voltage isolation is required, the bypass may have to actuate under AC-3 conditions (for example on removal of the Enable signal on terminal E2). In this case, ensure that a higher-level isolating element is actuated first or dimension the bypass to AC-3. In the recommended standard connections, the mains contactor and the soft starter Enable are maintained until the bypass contactor has safely disconnected. Then the starter and the mains contactor are shut down immediately. If the circuit is laid out according to these diagrams, an AC-1 bypass can therefore be used.

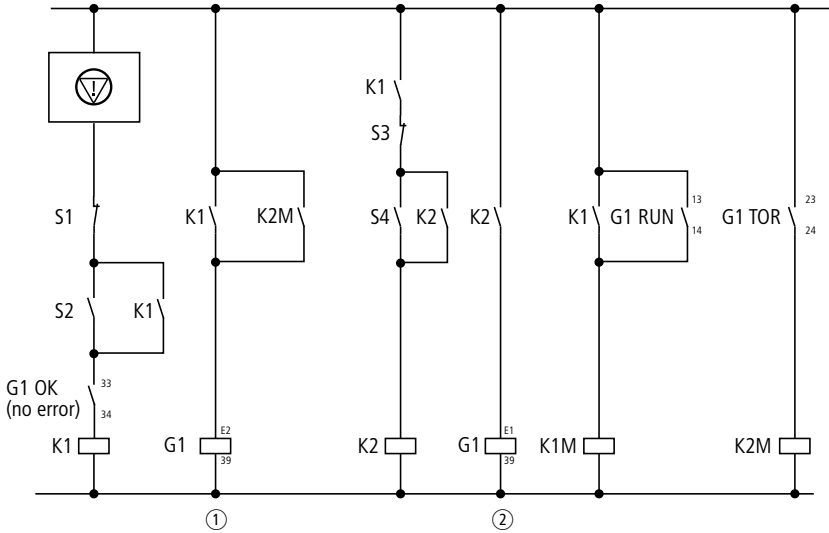

Figure 17: DM4-340 bypass, control circuit

- ① Enable DM4
- ② DM4 Soft start, Soft stop
- ⊖ : EMERGENCY STOP
- S1: Off
- S2: On
- S3: Soft stop
- S4: Soft start

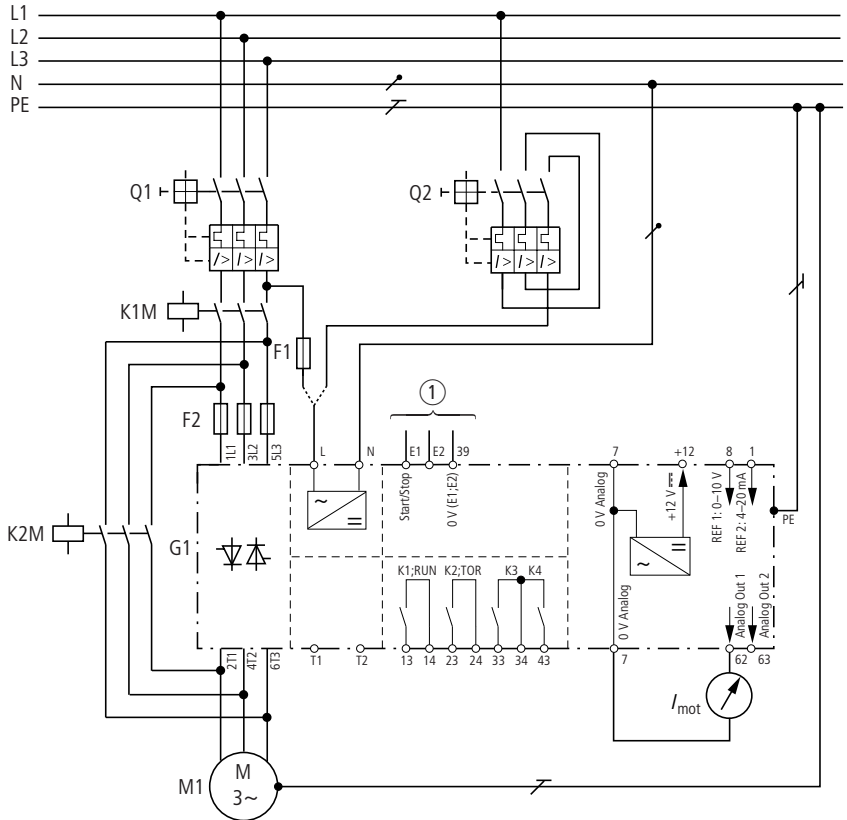

Figure 18: DM4-340 with bypass

- ① See actuation
- E2: Enable
- T1: +Thermistor
- T2: -Thermistor

### **Pump connection**

When pumps are used with the soft starter, it must be possible to frequently perform emergency operations with the bypass contactor. For selection between soft starter operation and direct start through the bypass contactor, a service switch is used. The soft starter is then fully isolated. Because it is not permissible to open the output circuit during operation, interlocks ensure that a changeover is possible only after a stop.



In contrast to simple bypass operation, a bypass contactor to AC-3 must be used in this case. The mains contactor recommended in the technical data (see appendix) can be used for this purpose.



Make sure that you set the protective function of the soft starter to Phase Failure Only or Start+Bypass, otherwise p. f. optimization is active, resulting in malfunction of the drive.

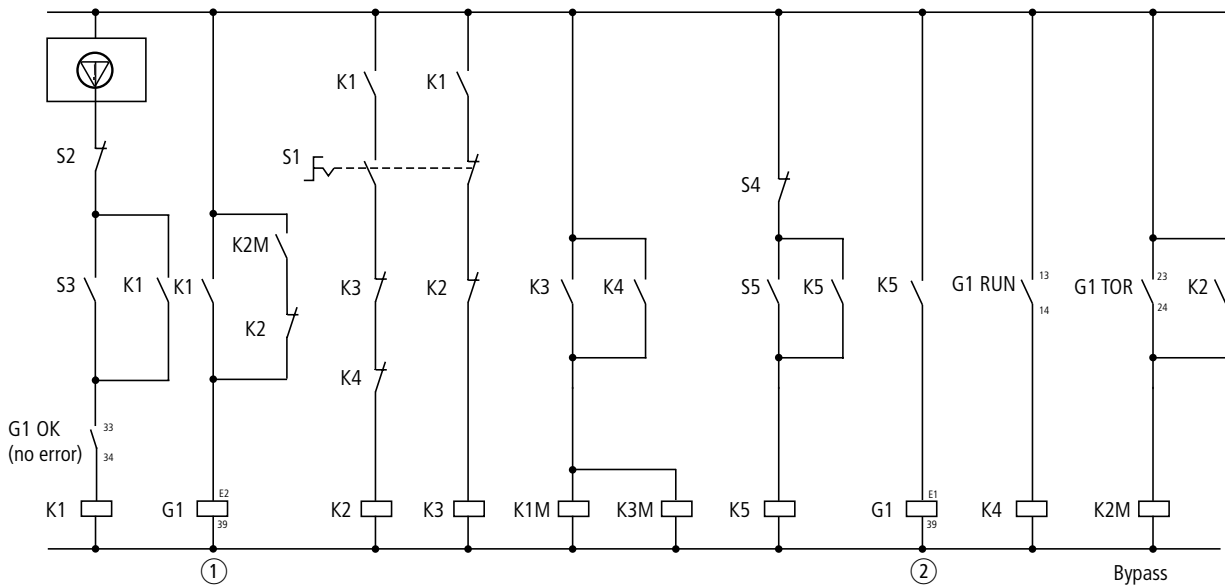

Figure 19: DM4-340 pump, actuation

- |                                    |                |
|------------------------------------|----------------|
| ① Enable DM4                       | S2: Off        |
| ② DM4 Soft start, Soft stop        | S3: On         |
| ⊖: EMERGENCY STOP                  | S4: Soft stop  |
| S1: Manual/Automatic<br>changeover | S5: Soft start |
|                                    | K2: Manual     |

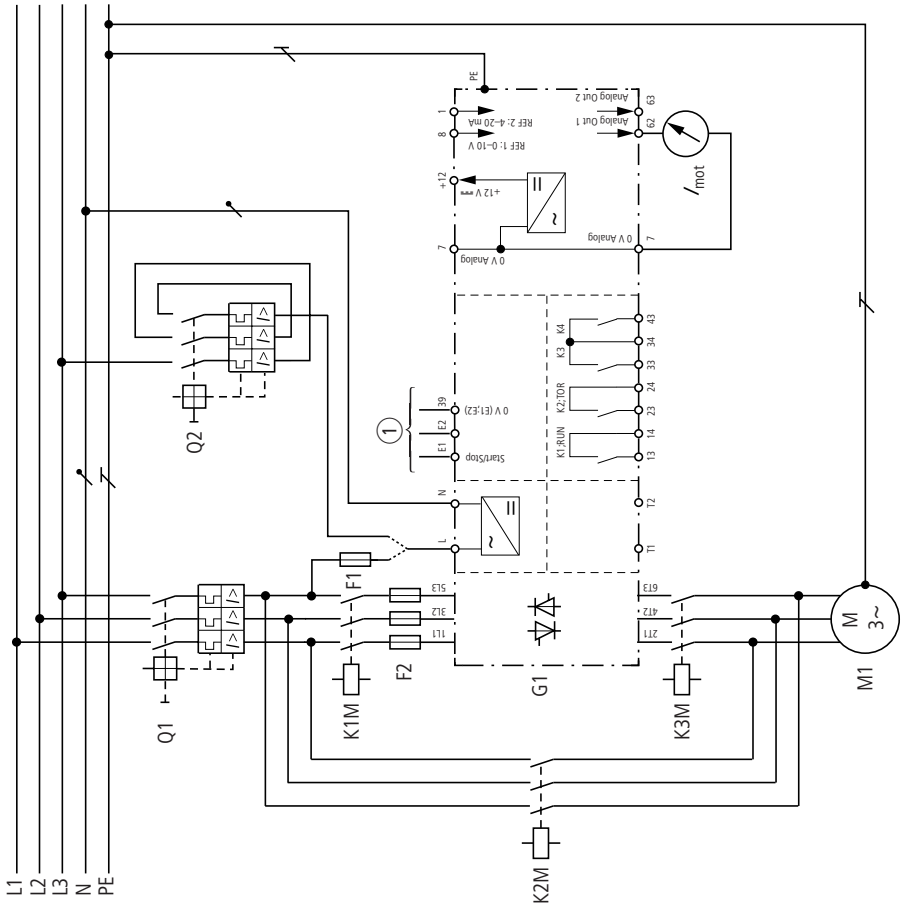

Figure 20: DM4-340 pump

- ① See actuation
- E2: Enable
- T1: +Thermistor
- T2: -Thermistor

### **In-delta connection**

In-delta connection reduces the required soft starter power at a given rated motor output. A series connection with the motor winding reduces the current by a factor of  $\sqrt{3}$ . The need for six motor supply cables are a disadvantage here. Apart from that, there are no limiting factors. All soft starter functions remain intact.

The motor must be connected in a delta configuration, and the voltage must correspond to the mains voltage, i. e. at a mains voltage of 400 V, the motor must be rated for 400 V/690 V.

- In this operating mode, p. f. optimization is not possible and must be disabled (see section "p. f. optimization (submenu)" on page 100). The permissible motor rating is listed in the technical data (see appendix).
- For In-delta connection, the Mode parameter must be changed to "1 = In-delta" with the DE4-KEY-2 keypad or one of the interface modules (see section "Configuration of controlled device" from page 79).
- When the stop ramp has completed or when the Enable signal is withdrawn, the mains contactor must be de-energized.



The power supply of the DM4 must separate from the supply of the motor. To change PNU 651, use the external DE4-KEY-2 keypad or the DE4-CFG-200 operating software with the DE4-COM-2X interface module. These are not part of the standard soft starter package content.

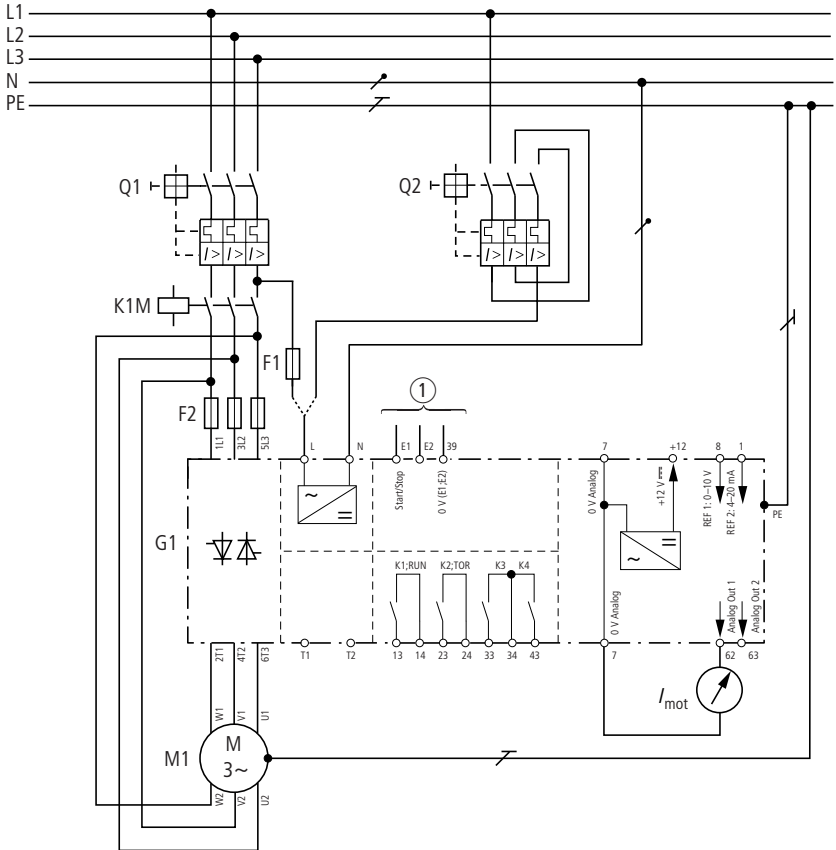

Figure 22: DM4-340 In-delta

- ① See actuation
- E2: Enable
- T1: +Thermistor
- T2: -Thermistor

Reversing circuit

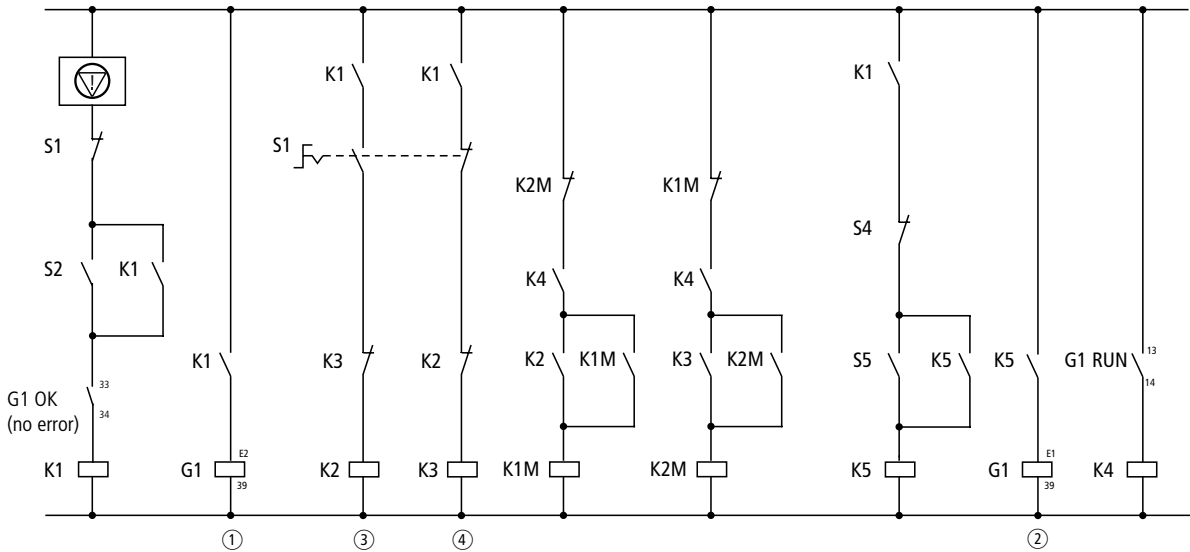

Figure 23: DM4-340 reversing circuit, actuation

- |                             |                            |
|-----------------------------|----------------------------|
| ① Enable DM4                | S1: Off                    |
| ② DM4 Soft start, Soft stop | S2: On                     |
| ③ Forward                   | S3: Direction preselection |
| ④ Reverse                   | S4: Soft stop              |
| ⊖: EMERGENCY STOP           | S5: Soft start             |

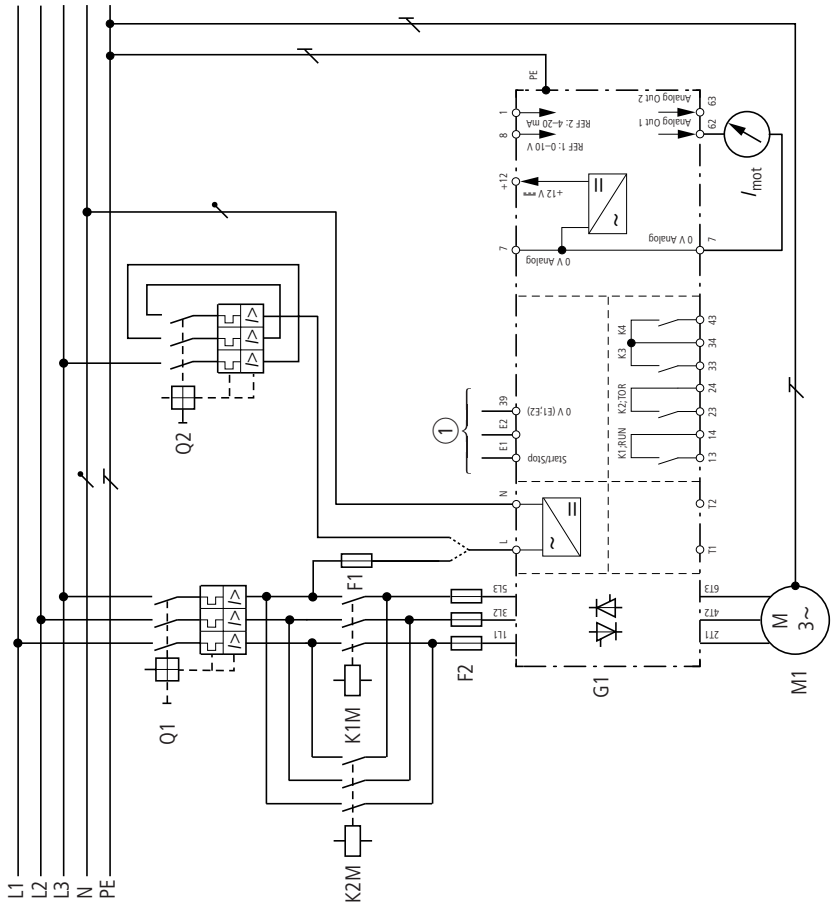

Figure 24: DM4-340 reversing circuit

- ① See actuation
- E2: Enable
- T1: +Thermistor
- T2: -Thermistor

The external reversing contactor is switched over only after completion of the soft stop ramp.

**Starting several motors in succession with a soft starter**

When starting several motors in succession with a soft starter, observe the following order for changeovers:

- Start with soft starter
- Switch on bypass contactor
- Disable soft starter
- Switch soft starter output to next motor
- Restart

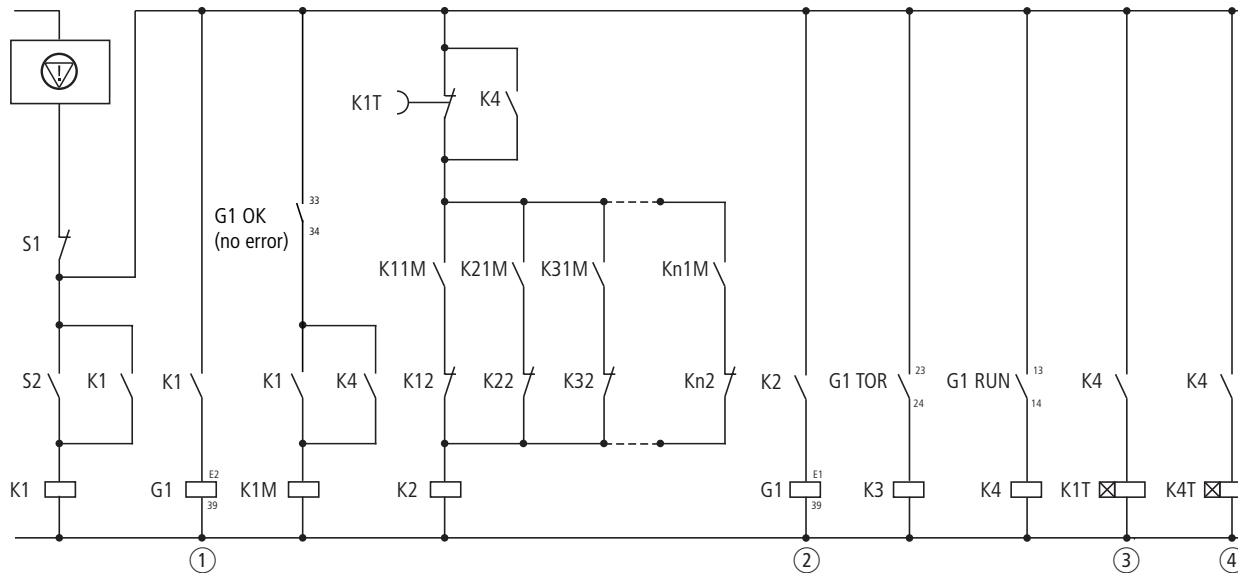

- ① Enable
  - ② Soft start, Soft stop
  - ③ Set the time relay so that the soft starter does not suffer thermal overload. The appropriate time depends on the permissible operating frequency of the selected soft starter. Otherwise, select a soft starter that allows the required times to be achieved.
  - ④ Set the timing relay to about 2 s returning time. This ensures that the next motor branch cannot be connected while the soft starter is running. Break contact S1 switches all motors off at the same time. Break contact S3 is required if you also want to switch motors off individually.
- :EMERGENCY STOP  
 S1: Off  
 S2: On

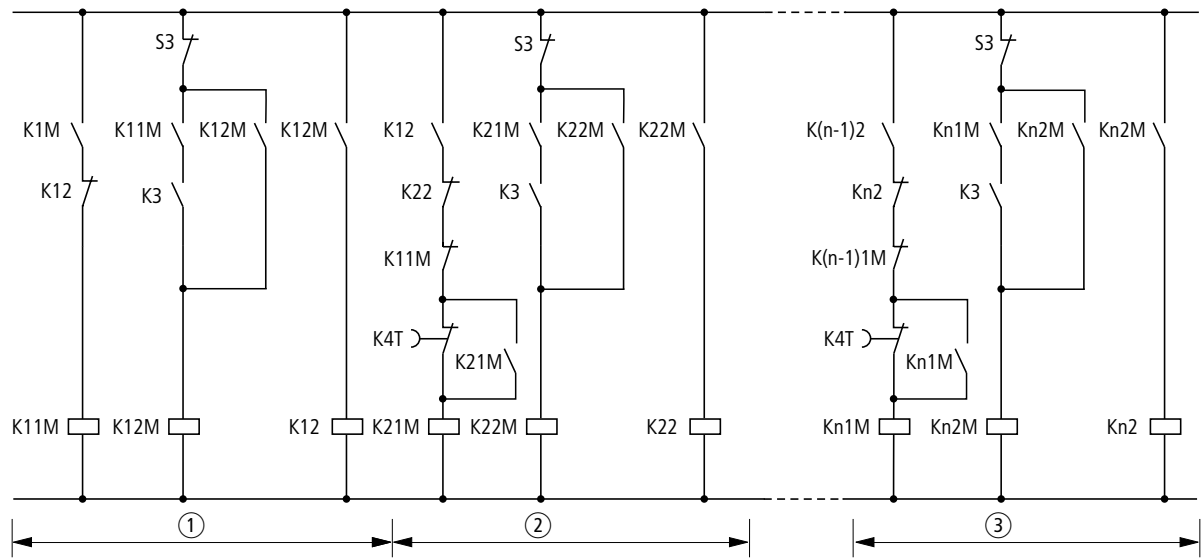

- ① Motor 1
- ② Motor 2
- ③ Motor n

Figure 25: DM4-340 cascade, control circuit part 1

Figure 26: DM4-340 cascade, control circuit part 2

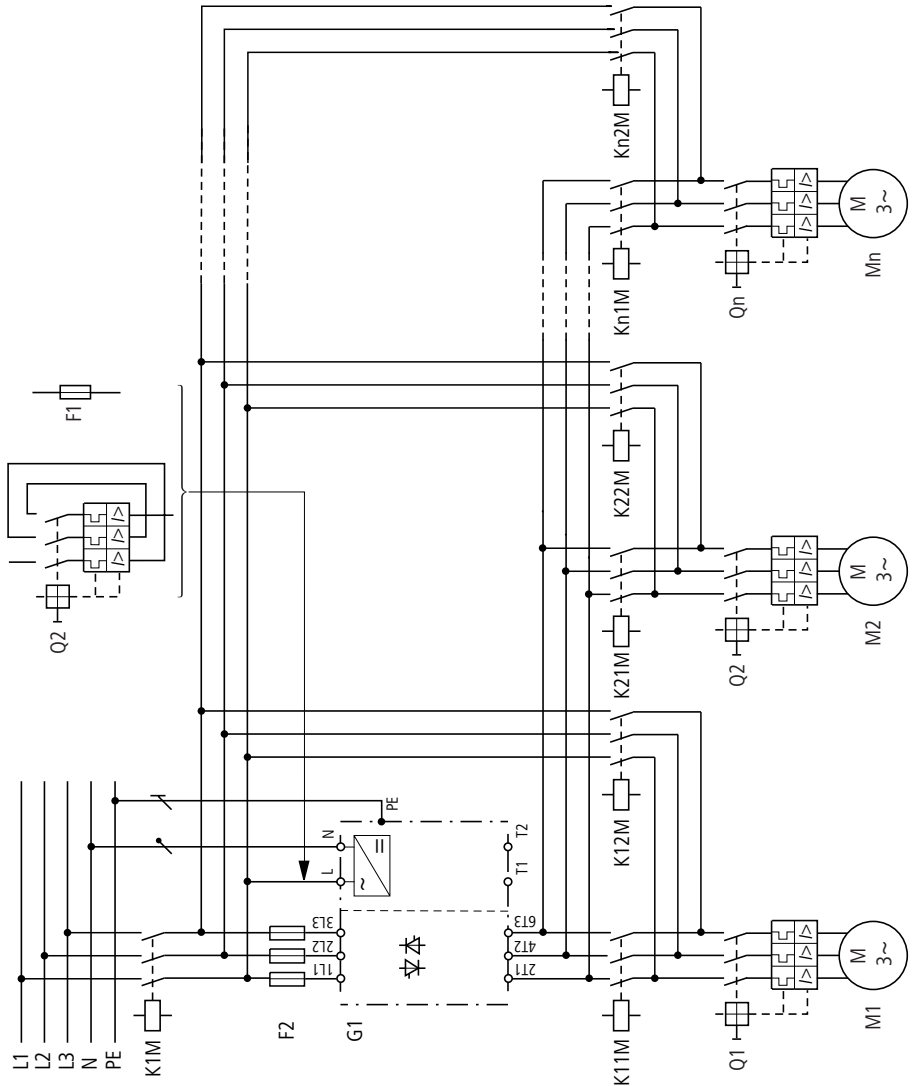

Figure 27: DM4-340 cascade

T1: +Thermistor

T2: -Thermistor

Take into account the thermal load on the soft starter (start frequency, current load). You may have to select a soft starter capable of handling a higher load cycle.

### Connecting motors to a soft starter in parallel

You can also start several motors in parallel with a soft starter. The behaviour of individual motors cannot, however, be influenced in this case. Each motor should be fitted with suitable overload protection.



#### Warning!

In case of a fault, disable the soft starter rather than switching motors off individually, since the voltage peaks generated in the latter case can destroy the soft starter.



The total current consumption of all connected motors must not exceed the soft starter's rated operating current  $I_e$ .



When several motors are connected in parallel, you can not use the soft starter's electronic motor protection function. In that case, protect each motor individually with thermistors and/or overload relays.

**Warning!**

The soft starter's output must not be switched, since the resulting voltage peaks could destroy the thyristors in the power section.

If motors with large differences in rated power (for example 1.5 kW and 11 kW) are connected in parallel to the output of a soft starter, problems may arise at startup. In some cases, the motor with the smaller rated power may be unable to produce the required torque. Due to the relatively large resistive load in the stators of these motors, they require a higher voltage during startup.

**Connecting the controller****Controller supply voltage (rated control supply voltage  $U_c$ )**

With a slide switch, match the controller supply voltage (terminals L, N) to the corresponding supply voltage of either 110 V AC or 230 V AC. Move the slide switch into the appropriate position.



Before switching on, check that the set voltage is the same as the supply voltage.

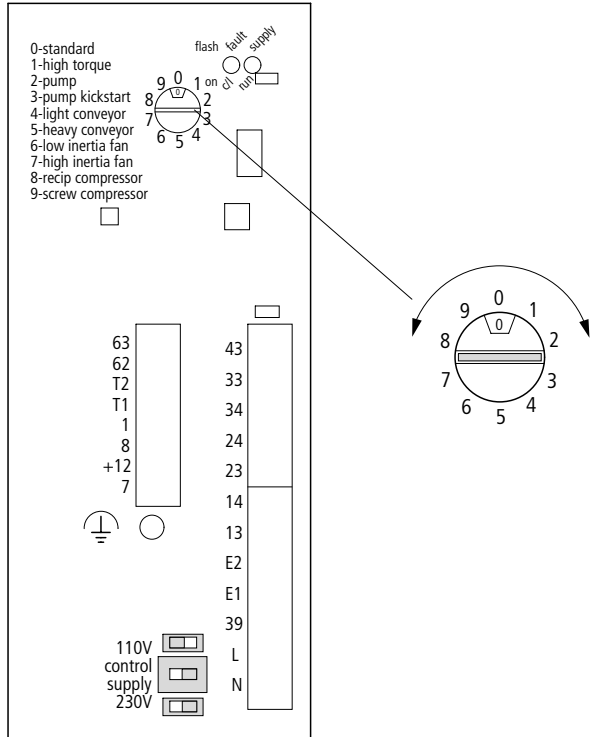

Figure 28: Controller supply switch

### Internal voltages

The DM4 series soft starters provide an internal voltage, which is available at the following terminals:

- Terminal +12:  
for analog reference value input in open-loop operation and as supply for the digital inputs
- Terminal 7:  
0 V potential (linked to PE)

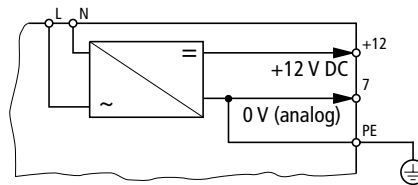

Figure 29: Internal voltage source

### Earthing the zero potential (terminal 39)

If you are supplying the control signals (E1, E2) with the internal +12 V, you must earth terminal 39 (= 0 V potential of terminal E1, E2). Select a cable with a cross-section of at least  $1.5 \text{ mm}^2$  (connection to same 0 V bus as terminal 7).

If the control signals are supplied with external 230 V, connect terminal 39 to the control voltage reference potential.

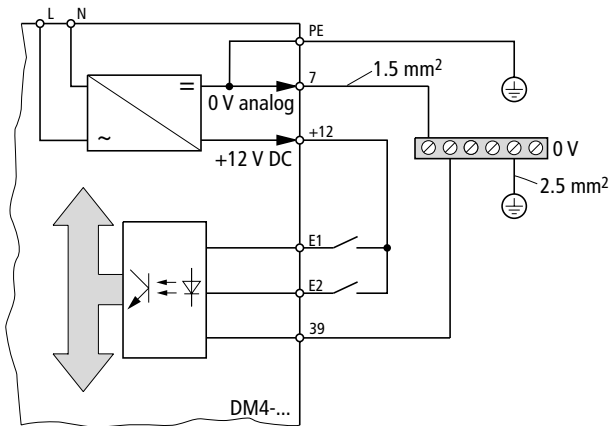

Figure 30: 0 V for control signal terminals

To install several soft starters or automation devices in a system, the zero potentials of each of the devices must be interconnected point-to-point in a star configuration. Each of the devices must have a common ground at the "weakest" component, for example a PLC.

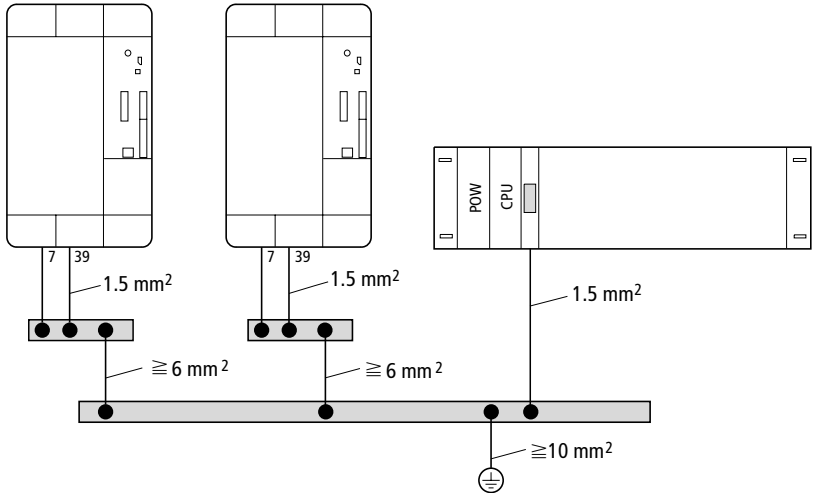

Figure 31: Grounding in star configuration

### Digital inputs, PLC interconnection

The digital inputs of the DM4 series soft starters are opto-isolated and galvanically isolated from the control section. This allows them to be directly connected to a programmable logic controller (PLC). To increase their interference immunity, the zero potential of the control signal inputs (terminal 39) can be connected directly to ground through an unpolarized capacitor (0.1  $\mu\text{F}$ , 250 V DC).

If terminals E1 and E2 are supplied through an external voltage from a PLC, connect the 0 V potential of the PLC outputs and the 0 V potential of the control inputs (terminal 39) with each other.

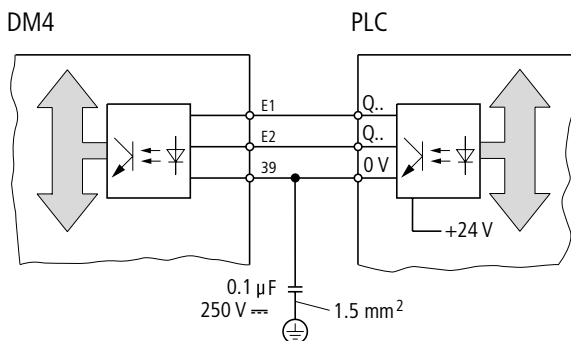

Figure 32: Connecting a PLC

If several soft starters are controlled by the same PLC within a system, connect the zero potentials of all devices point-to-point in a star arrangement. The devices must have a common ground at the "weakest" element, i. e. the PLC. In addition, if you experience any problems, connect terminal 39 of each soft starter through a capacitor. The zero potential of the PLC can be grounded directly.

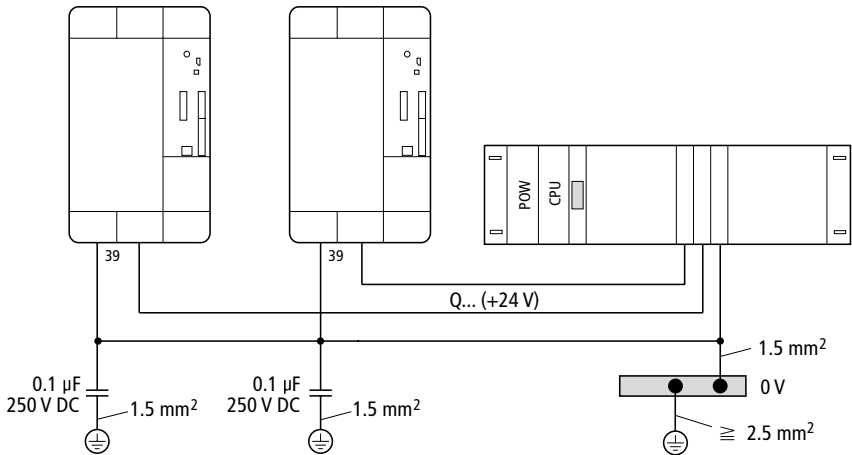

Figure 33: Grounding when a PLC is used

### Inputs for analog setpoint values

The analog reference values are normally used only in open-loop control mode.

However, you can also provide an internal signalling threshold for external voltage and current values to trigger control functions. A current temperature value, for example, (0 to 10 V DC) can be used to disable the soft starter at a specific temperature or to set a relay output.

The reference value can be specified with an analog signal through input terminals 7 (0 V) and 8 (0 to 10 V DC) or through terminal 1 (4 to 20 mA).



Terminal 7 (0 V of the analog inputs) is connected directly with PE (functional ground).

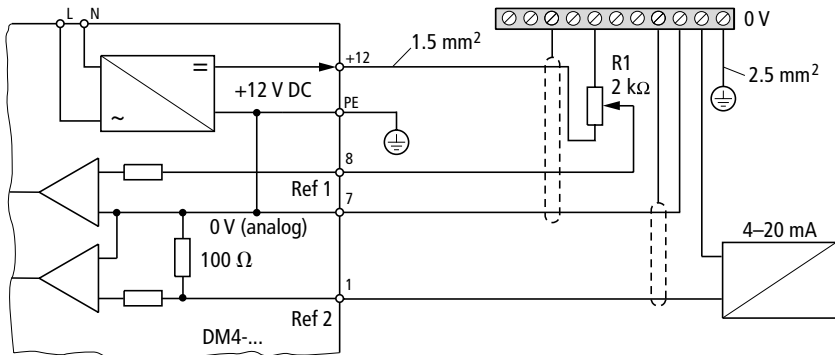

Figure 34: Setpoint value connection

### Reference input value definition with current signal

Because terminal 7 is connected directly to PE (functional ground), it is not possible to transmit a default reference variable to more than one device. At the second starter, the signal input (terminal 1) and the reference point (terminal 7) would be short-circuited through terminal 7, which is PE of the first device. The reference variable for current can therefore be used only for a point-to-point connection.

The internal load resistance is 100  $\Omega$ .

### Analog outputs

You can connect analog measuring instruments to terminal 62 and terminal 63. Use the parameters to define the monitor signal to be displayed. By default, the motor current is output on terminal 62, and the delay angle on terminal 63. The maximum voltage range at both terminals is 0 to 10 V, 10 mA.

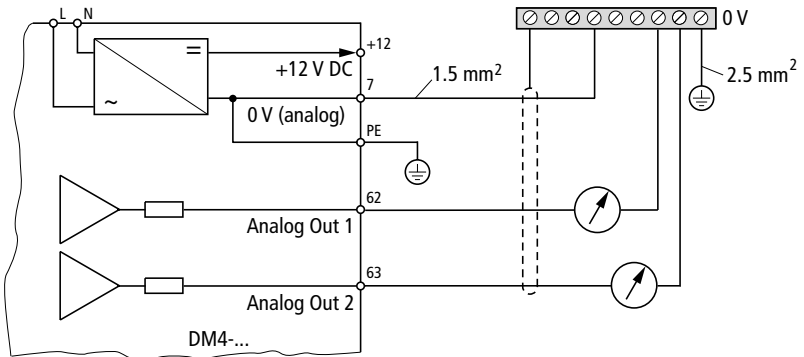

Figure 35: Analog output connections

## Relay contacts

The DM4 soft starters have four relays with a make contact. The signal assignment can be programmed. The relay contacts are galvanically isolated from the soft starter. Relays K1 and K2 are floating relative to each other. Relays K3 and K4 share a common terminal, but are floating relative to K1 and K2.

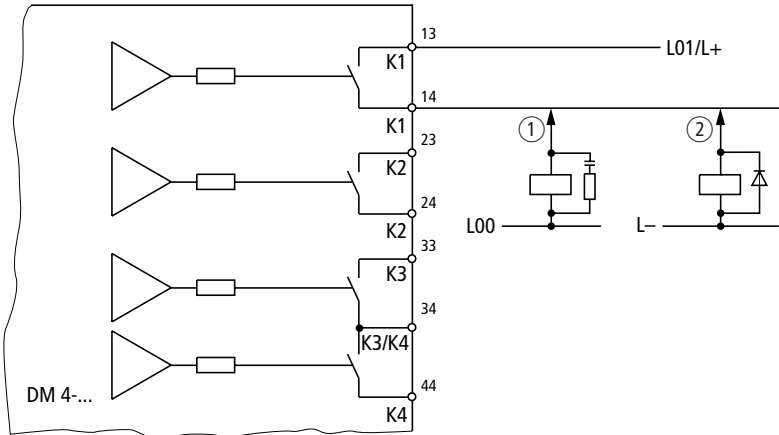

Figure 36: Relay connection

- ① Suppressor circuit for AC control voltage
- ② Suppressor circuit for DC control voltage

Terminal	Standard function	Assignment	Use	Rating
13	Run	Input K1	Programmable make contact	230 V AC, 3 A, AC-11
14		Output K1		
23	TOR (top of ramp)	Input K2		
24		Output K2		
33	Alarm	Output K3		
34		Input K3 and K4		
43	Overload reaction	Output K4		

When you connect external contactors to a relay contact, you can increase the interference immunity by connecting

- an RC filter in parallel to the contactor coil in AC circuits;
- a free-wheel diode in parallel to the contactor coil in DC circuits.



### 3 Defining Parameters

---

#### Principles of operation

You can use parameters to adapt the soft starter to your application. The settings are grouped into different parameters with unique parameter numbers (PNU).

Device parameters are defined either with

- the application selector switch,
- interface modules, or
- the keypad of the DE4-KEY-2 keypad.

The LCD keypad and the serial interface modules are both available as accessories.

The DM4-340 series has two parameter sets. To reference the second parameter set (PAR 2), add an offset of 2000 to the parameter number from PAR 1. The following functional descriptions refer to the parameter numbers of the first parameter set (PAR 1). Parameter numbers of parameters that can have an independent value in the second parameter set (PAR 2), are given in square brackets in the tables. All other parameter numbers above 2000 are set internally to the corresponding parameter of the first parameter set.



The information in this manual applies to the software from version 52.09 or later (PNU 99).

Example:

PNU 12 belongs to the first parameter set. The same parameter in the second parameter set has PNU 2012.



On the DM4 soft starter, you can make most parameter changes only with activated controller inhibit.



Any parameter changes are applied when the input is confirmed (with Shift + PRG on LCD keypad DE4-KEY-2), but are lost when the power supply is switched off. To save the parameters permanently, program parameter Parameterset with the value "1" in the Config/Control menu ("save Para." = save parameter set).

### Display of special characters on the LCD keypad

Due to its dot matrix size, the LCD keypad cannot display some special characters for certain languages. Special feature:

- Accented upper case characters (such as "Ü") are displayed as their lower-case equivalent (here: "ü").

In the following sections and tables, the parameter name will always be represented as it appears on the keypad display.

### Application selector switch

With this switch on the front of the device, preset parameter sets can be selected for different applications. One standard and nine application-specific settings are available. If necessary, you can use the LCD keypad or interface to make fine adjustments to the default settings. The following applications can be selected:

Labelling on the device	Display on the LCD keypad	Use	Notes
0-Standard	Standard	Standard	Default setting, suitable without changes for most applications
1-High torque <sup>1)</sup>	High torque	High breakaway torque	Drives with increased breakaway torque
2-Pump	Small pump	Small pump	Pump drives up to 15 kW
3-Pump Kickstart	Pump W.Kick	Pump W.Kick	Pump drives over 15 kW; longer deceleration times
4-Light conveyer	LightConvey	Light conveyer	–
5-Heavy conveyer	Heavy conveyer	Heavy conveyer	–
6-Low inertia fan	LowInert.Fan	Low inertia fan	Fan drives with low mass inertia moment, max. 15 × inertia moment of motor
7-High inertia fan	HighInertFan	High inertia fan	Fan drives with high mass inertia moment, more than 15 × inertia moment of motor. Longer ramp-up times
8-Recip compressor	RecipCompres	Reciprocal (piston) compressor	Increased starting voltage, adapted for p. f. optimization.
9-Screw compressor	Screw compressor	Screw compressor	Increased current demand; No limit current

- 1) A prerequisite for the “High torque” setting is that the soft starter can always deliver 1.5 times more current than the motor’s rated current.

If the LCD keypad is fitted, the rotary switch is not accessible. The application can then be selected in the corresponding submenu on the LCD keypad.

The pre-programmed parameter sets for applications change the following parameters to the specified values:

## Defining Parameters

PNU	Name	Position of application selector switch									
		0	1	2	3	4	5	6	7	8	9
11	U-Start	20	60	10	25	10	40	30	40	45	40
12	t-Start	5	5	7	10	10	10	15	3	3	7
30	lmax-Start	3.5	4.5	3.5	3.5	3.5	3.5	3.5	2.81	3.5	7.9
31	t-lmax	30	15	25	25	20	30	30	60	25	25
16	U-Stop	10	10	10	10	10	10	10	10	10	10
17	t-Stop	0	0	30	45	5	7	0	0	0	0
19	Rate	5	5	5	5	5	5	5	5	15	5
627	Kickstart	0	0	0	1	0	0	0	0	0	0
628	Current limit	1	1	1	1	1	1	1	1	1	1
629	Overload reaction	1	1	1	1	1	1	1	1	1	1
630	OverCurrent	1	0	0	0	0	0	0	0	0	0
631	UnderCurrent	0	0	0	0	0	0	0	0	0	0
632	Thermistor	0	0	0	0	0	0	0	0	0	0
633	Command source	0	0	0	0	0	0	0	0	0	0
634	U-Stopramp	0	0	0	0	0	0	0	0	0	0
	U-Stopramp (from software version PNU 99 = 53.12)	0	0	1	1	1	1	0	0	0	0
641	Pf1 Logic	1	1	1	1	1	1	1	1	1	1
642	Pf2 Logic	1	1	1	1	1	1	1	1	1	1
643	Set lmax	0	0	0	0	0	0	0	0	0	0
644	ExtFault	0	0	0	0	0	0	0	0	0	0
645	AutoEndStop	0	0	0	0	0	0	0	0	0	0
646	AutoStopProf	0	1	1	1	1	1	1	1	1	1
647	AutoEndStart	0	1	1	0	0	0	1	1	1	1
648	AutoU-Start	0	1	1	0	1	1	1	1	1	1
669	SmoothStop	0	0	1	1	0	0	0	0	0	0

### Default settings of the basic unit

The default settings of the DM4 series soft starters are chosen such that no parameter changes are necessary for standard applications. The table below lists the key settings.



Except for the application selector switch and its possible positions, the following can be changed only with the LCD keypad or the interface modules.

Terminal, function	Default
E1	Start/stop
E2	Enable
Ramp times	t-Start: 5 s t-Stop: 0 s
Start pedestal	20 %, with automatic load adaptation
Analog Out 1	Motor current
Analog Out 2	Delay angle
Relay K1	Run
Relay K2	TOR: Top of ramp; rated voltage reached
Relay K3	Alarm
Relay K4	Overload operation
Operating mode	Start/stop through terminals, parameter selection with application selector switch

---

**Basic settings**

The Basic main menu contains the key data for adapting the starter to the required application. This main menu does not have submenus. The parameters are displayed directly.

The first parameter indicates the device and is displayed only for information.

Parameter Application performs the same task as the application selector switch.

If parameter Application is read, it always returns a zero value, independent of its real setting. Parameters which are changed when this parameter is written to can later be individually modified. When the Application parameter is written to again, these individual changes are, however, overwritten again.

With the remaining parameters in this menu, the key starting parameters can be adjusted if the default settings are not ideal.

PNU	Name	Value	Function	Def
113	Drive		Indicates the current soft starter type	–
1	Startcommand	0	Terminals start/stop, App. switch active, Key/options are read-only.	0
		1	Terminals start/stop, App. switch active, Key/options are read-only for app. parameters, read/write for other parameters.	
		2	Terminals start/stop, App. switch inactive, Key/options are read/write for all parameters.	
		3	Key/options start/stop, App. switch inactive, Key/options are read/write for all parameters.	
115	Application	0	Standard	
		1	High torque	
		2	Small pump	
		3	Pump W.Kick	
		4	LightConvey	
		5	Heavy conveyor	
		6	LowInert.Fan	
		7	HighInertFan	
		8	RecipCompres	
		9	Screw compressor	
11 [2011]	U-Start [U-Start 2]	10 to 60 %	Voltage at which soft start function begins.	20 %
12 [2012]	t-Start [t-Start 2]	1 to 255 s	Ramp time to 100 % input voltage	5 s
17 [2017]	t-Stop [t-Stop 2]	0 to 255 s	Ramp time to 0 % output voltage	0 s
30 [2030]	Imax-Start [Imax-Start 2]	1.0 to 8.0 $I_e$	Current limiting value at start in multiples of device rated current $I_e$	3.5 $I_e$

**Defining Parameters**

<b>PNU</b>	<b>Name</b>	<b>Value</b>	<b>Function</b>	<b>Def</b>
66	Language		Select display language	49
		34	Spanish	
		39	Italian	
		44	English	
		49	Deutsch	
62	Parameterset	1	Save parameters	-
		2	Default	
		3	Load power-on parameters	

## Configuring the basic unit Control (submenu)

The Configuration main menu contains two submenus, which in turn contain the Parameters for configuring the basic unit.

As supplied, the soft starter's parameters can be configured only with the application selector switch.

With "Startcommand", the channel through which control and parameter configuration is to take place is defined. If "Terminal Start/Stop" is selected, any start/stop command entered on the keypad is ignored.

PNU	Name	Value	Function	Def
1	Startcommand	0	Start/Stop terminals, app switch active, key/options read-only.	0
		1	Start/Stop terminals, app switch active, key/options read-only for App parameters, read/write for other parameters.	
		2	Start/Stop terminals, app switch not active, key/options read/write for all parameters.	
		3	Key/options Start/Stop, app switch not active, key/Options read/write for all parameters.	

### Network operation

#### (from software version PNU 99 = 53.12)

If parameter PNU 001 is set to 3, the DM4 is controlled through the network option (start, stop, etc.). The use of this parameter is described in section "Parameters outside the menu structure" on page 133.

### Mode

The control mode determines the basic function of the device. The default setting is soft starter operation. Alternatively, the soft starter can work as a phase controller. There are two options:

- Open- or closed-loop
- controller



### Warning!

The Phase Control functions are not intended for motor speed control. The motor can be damaged if generalized phase control is used to regulate its speed (i. e. slip regulation: at low speeds, extreme power dissipation occurs in the motor).

If a setpoint is used directly in open-loop control mode to specify an output voltage, a closed control circuit is established in closed-loop control mode. By default, the output current is looped back. However, you can also program another value, for example the second analog input or a constant.

If the DM4 is operated in one of the two control modes (open-loop or closed-loop), you must also specify whether or not the load has an earthed star point (or connection to neutral). The control is then adapted accordingly. If the setting is not correct, incorrect control actions result.

If the load is connected with a delta circuit, settings 4 and 5 are not permissible.

PNU	Name	Val.	Function	Def
6	Mode	0	Standard soft starter	0
		1	Soft starter "in-delta"	
		2	ClosedLoop	
		3	Open-loop phase control	
		From software version PNU 99 = 53.12:		
		4	Regulator with earthed star point	
		5	Controller with earthed star point/ connection to neutral	

### Password

On delivery, the soft starter is not password-protected and all parameters can be changed. Once a password has been set, the password must be entered before any parameters can be changed.

The password is not shown on the display. If "255" appears here, no password has been set. Otherwise, the password is displayed in encoded form.

The encrypted display has a value range up to 1255.

PNU	Name	Value	Function	Def
5	Password	0 to 1255	Password input	0 Encrypted indication on the display: "255"

Enter password:

- ▶ To set a password, select the Password parameter in the Config/Control menu.
- ▶ Enter a number between 1 and 255.
- ▶ To save the password permanently, press Shift+PRG.

You do not need to perform the Save Parameter function. If the correct password is entered, the message "OK" appears; if an incorrect password is entered, the display reads "NOT OK".

If a value 1xxx is displayed, the password is active and you cannot change parameters. When you enter the active password, the display changes to xxx. This means that a password has been set. When you enter the correct password, it is temporarily disabled. You can then change or delete the password and change the parameter. When the device is switched on again, the old password is active again unless you have changed or deleted it.

Changing the password:

- ▶ Enter the current password and confirm with Shift+PRG.
- ▶ When "OK" appears on the display, enter a new password.

Removing the password:

- ▶ Enter the current password and confirm with Shift+PRG.
- ▶ When "OK" appears on the display, enter "0" (zero) as the new password.

The display now reads "255" again, indicating that the password has been reset.

Accessing parameters with password protection:

When a password has been set, parameters can be viewed but not modified, and the programming mode is disabled (operator panel). Write access to the parameters is also disabled for the LCD keypad and the interface modules.



No special message appears if parameters cannot be changed. On the display, the "SHPRG" symbol no longer appears next to the parameters.

To be able to change parameters, you must correctly enter and save the Password parameter. Parameters can then be modified until the power supply is switched off. Once power is disconnected, the password becomes active again.

Forgotten password:

If the "SHPRG" symbol does not appear next to parameters that can normally be edited, then all parameters – with a few exceptions – behave like read-only parameters, a password has been set. If you have forgotten the password, it can be calculated from the displayed value:

$A = 1255$  – (displayed password value)

If A is even:

$$\text{Password} = \frac{A}{2}$$

The calculated value is the actual password.

If A is odd:

$$\text{Password} = \frac{(A + 256)}{2}$$

Remove the digits after the decimal point to obtain the actual password.

### Parameter set

With the LCD keypad, parameter changes can be saved permanently in the soft starter. Three options are available for the Parameter set parameter:

PNU	Name	Value	Function	Def
62	Parameterset	1	Save parameters	–
		2	Default	
		3	Load power-on parameters	

### Save parameters

The current settings are saved permanently in the soft starter. The changed values are not lost when the supply voltage is disconnected and are reloaded the next time power is switched on again.

#### Default (load default settings):

With this function, the default parameters are reloaded. As long as they are not saved permanently, the previously active parameter set is reloaded when power is switched off and on again.

#### PowerOn Para (load Power On parameters):

If changes are made during soft starter operation, results may deteriorate. With this function, all changes made since the supply voltage was first switched on or the last time changes were saved can be reversed. This function has the same effect as switching the supply off and on again.



If you have changed parameters without running the Save Parameters function (save Para.), all changes are lost when the supply voltage is disconnected. Depending on the soft starter's required parameter settings, soft starter or PLC malfunction can result.

**Parameter set transfer**

PNU	Name	Val.	Function	Def
2	KEY->PAR	20	Load parameter data from the LCD keypad.	–
3	PAR->KEY	11	Save parameter data to the LCD keypad.	–

**KEY->PAR:**

This function reads the parameters from the LCD keypad and copies them to the soft starter. To save the parameters permanently, the Save Parameters function must be run.

**PAR->KEY:**

This function copies the parameters from the soft starter to the LCD keypad.

**Select parameter sets**

The DM4-340 series has two parameter sets that can be switched in when the soft starter is disabled. With them, additional soft start and soft stop times or current limits and start voltages become available. Each parameter set contains all parameters relevant to starting. This function can be selected directly on the LCD keypad. Alternatively, one of the two digital inputs can be configured for this function.

PNU	Name	Val.	Function	Def
639	PAR1/PAR2	0	PAR 1	0
		1	PAR 2	

To select the parameters of the second parameter set, add 2000 to the parameter numbers.

Some parameters do not have independent values in the second parameter set. When these parameters are accessed, they are automatically replaced with the values from the first set.



If you have switched to PAR2, the parameter name shown in square brackets [...] in the table below is displayed on the LCD keypad. Due to system limitations, the number from PAR1 will continue to be shown. All changes will, however, be applied to PAR2.

The following parameters can have different values in PAR1 and PAR2:

Brief description of parameter	Parameter name on display	PNU
Protection	Protection [Protection 2]	7 [2007]
Start pedestal	U-Start [U-Start 2]	11 [2011]
Start time	t-Start [t-Start 2]	12 [2012]
Kickstart voltage	U-Kick [U-Kick 2]	13 [2013]
Kickstart time	t-Kick [t-Kick 2]	14 [2014]
Dwell	t-Dwell [t-Dwell 2]	15 [2015]
Stop pedestal	U-Stop [U-Stop 2]	16 [2016]
Stop time	t-Stop [t-Stop 2]	17 [2017]
Undercurrent	Imin [Imin 2]	28 [2028]
Undercurrent time	t-Imin [t-Imin 2]	29 [2029]

## Defining Parameters

Brief description of parameter	Parameter name on display	PNU
Current limit reaction	lmax-Start [lmax-Start 2]	30 [2030]
Current limit time	t-lmax [t-lmax 2]	31 [2031]
Overcurrent limit	OverCurr.max [OverCurr-Max2]	32 [2032]
Overcurrent time	t-Overcurr. [t-Overcurr2]	33 [2033]
Overload limit	Overload max [OverloadMax2]	34 [2034]
Overload time	t-Overload [t-Overload 2]	35 [2035]
Kickstart	Kickstart [Kickstart 2]	627 [2627]
Current limit reaction	Current limit [CurrentLim.2]	628 [2628]
Overload reaction	Overload [Overload 2]	629 [2629]
OverCurrent	OverCurrent [OverCurrent 2]	630 [2630]
Undercurrent reaction	UnderCurrent [Undercurr.2]	631 [2631]
Thermistor reaction	Thermistor [Thermistor 2]	632 [2632]
Stop ramp control	U-Stopramp [U-Stopramp2]	634 [2634]
Invert reference	InvertRef0 [InvertRef0 2]	635 [2635]
Auto end stop	AutoEndStop [AutoEndStop2]	645 [2645]
Auto stop	AutoStopProf [AutoStopPrf2]	646 [2646]

Brief description of parameter	Parameter name on display	PNU
Auto end start	AutoEndStart [AutoEndStrt2]	647 [2647]
Auto start pedestal	AutoU-Start [AutoU-Start2]	648 [2648]
Automatic recognition of connected bypass	AutoBypass [AutoBypass 2]	655 [2655]
Torque (from software version PNU 99 = 53.12)	Torque [Torque 2]	670 [2670]
Ignore parameter t-Start and work with zero value (from software version PNU 99 = 53.12)	t-Start = 0 [t-Start = 0 2]	671 [2671]

**Misc (submenu)****Language selection**

On the LCD keypad, you can choose the language in which messages are displayed. To select a language, enter the international dialling code in the appropriate parameter. You can choose between two (software versions before PNU 99 = 53.12) or four languages (from software version PNU 99 = 53.12).

PNU	Name	Value	Function	Def
66	Language	34	Spanish	49
		39	Italian	
		44	English	
		49	German	

**Device address, baud rate**

The device address allows specific bus stations to be addressed individually. The address is stored in this parameter. The parameter is only relevant in network operation, for which interface module DE4-NET-xxx is required.

PNU	Name	Value	Function	Def
9	Address	1 to 99	Device address for communication modules	1
125	Baud rate		Baud rate	0

**Nominal device current**

PNU 24 " $I_e$ " must be changed only by Moeller service personnel, since it requires additional hardware changes to be made. This parameter is used for adapting a larger device to a smaller motor for extreme startup conditions.

### Communication behaviour

With PNU 126, the soft starter's behaviour after an interruption to communications with the interface module (due to disconnection of or a fault in the interface module) can be specified to prevent subsequent uncontrolled operation of the soft starter. This parameter is used only when PNU 1 (Startcommand) has a value of 3 and a network module has been installed. For all other settings of PNU 1 = 0, this parameter has no significance.

PNU	Name	Value	Function	Def
126	Bus error	0	Continue	1
		1	Shutdown	

With PNU 126 = 0, no fault message is displayed after an interruption in communications between soft starter and interface module. The soft starter stays in its current state. As soon as the connection has been re-established, a reinitialization is automatically performed.

With PNU 126 = 1, a "Bus fault" message is displayed after an interruption in communications. The soft starter goes into the "Controller inhibit" state, i. e. the drive coasts to a halt. A reinitialization takes place only once the connection is re-established and a reset is performed.

### Initial display parameter

The parameter whose number is stored in PNU 4 (Init.Display), is shown on the lower line of the LCD keypad when the device is in operation mode.

PNU	Name	Value	Function	Def
4	Init.Display	20 to 111	Initial display parameter	26

## Defining Parameters

**Open and closed-loop control functions**

The Functions main menu contains ten submenus, through which the open and closed-loop control parameters can be accessed for the basic unit.

**StartData (submenu)**

PNU	Name	Value	Function	Def
11 [2011]	U-Start [U-Start 2]	10 to 60 %	Voltage at which soft start function begins.	20 %
12 [2012]	t-Start [t-Start 2]	1 to 255 s	Ramp time to 100 % input voltage	5 s
16 [2016]	U-Stop [U-Stop 2]	10 to 60 %	At this voltage, the stop ramp ends.	10 %
17 [2017]	t-Stop [t-Stop 2]	0 to 255 s	Ramp time to 0 % output voltage	0 s
634 [2634]	U-Stopramp [U-Stopramp2]	0	Off	0
		1	Run stop ramp voltage-referenced	
640	Tmp t-Stop=0	0	Off	0
		1	Overwrite soft stop.	
648 [2648]	AutoU-Start [AutoU-Start2]	0	Off	0
		1	Automatic start pedestal adaption	
647 [2647]	AutoEndStart [AutoEndStrt2]	0	Off	0
		1	Automatic end of start ramp when TOR reached prematurely by motor	
646 [2646]	AutoStopProf [AutoStopPrf2]	0	Off	0
		1	Adapt soft stop profile to load	
645 [2645]	AutoEndStop [AutoEndStop2]	0	Off	0
		1	Automatic end of stop ramp	

PNU	Name	Value	Function	Def
<b>From software version PNU 99 = 53.12</b>				
670 [2670]	Torque	0 = normal	Drive method for high starting torque.	0
		1 = high		
669	SmoothStop	0 = Off	Suppress vibrations on soft stop	0
		1 = On		
122	SmoothRate	1 to 25	High values result in stronger smoothing	5

The ramp times and the start pedestal have a marked effect on the starting behaviour. With increasing ramp times, the thermal load on the motor also rises. The ramp times should therefore be no longer than required by the machine.

Here are two examples:

- Conveyor belts:  
set time only as long as required to prevent transported items from falling over.
- Belt drives:  
set time only as long as required to prevent belt slippage.

To prevent unnecessary delay of the stop ramp, the initial voltage is rapidly reduced by an internally determined value when the AutoStopProf function is active. This ensures that the stalling torque is bypassed so that the delay can begin immediately. If AutoStopProf = 0, the soft stop function begins at 100 % mains voltage. At the drive, this results in a short delay before the motor speed changes after the Stop command before the ramp begins and the motor evenly decelerates.

If  $U\text{-Stopramp} = 1$ , the voltage is ramped down to the value of  $U\text{-Stop}$ . This ensures a gentle stop of motors with a high load. If the motor load is low, however, oscillations can result. When  $U\text{-Stopramp} = 0$ , the voltage is ramped down to a value determined by the soft starter. As a rule, this value is higher than  $U\text{-Stop}$ . When the switching threshold is reached, the soft stop is terminated and the power section inhibited. The motor then spins down by itself.

With actuation with high breakaway torque (such as long conveyors), an additional breakaway pulse may be necessary. This is provided by the Kickstart function.

With function  $Tmp\ t\text{-Stop} = 0$ , the soft stop ramp is temporarily overwritten with 0 s if the soft stop command is issued within 1 s of the soft start command, thereby reducing the time to the next start.

With  $AutoU\text{-Start}$ , the soft starter determines whether the motor can generate any torque at all. If the start pedestal is too low, the start is delayed and the motor heats up unnecessarily. If this function is active and soft starter determines that the motor is not generating torque, it rapidly increases the startup voltage to a value at which the motor can generate torque.

$AutoEndStart$  terminates the start ramp if the motor has already reached its full speed before its rated voltage is reached (for example idling motors, machines at partial load).

$AutoEndStop$  ends the soft stop ramp if the soft starter determines that the motor is continuing to run at low speed without decelerating at the current output voltage.

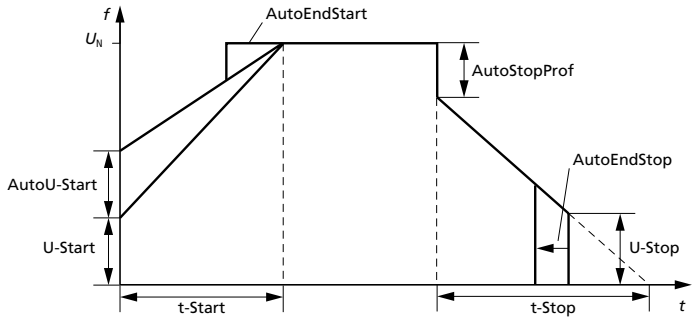

Figure 37: Start time/start pedestal

The Torque function is only effective if it is set to 1 = high and the start pedestal  $U\text{-Start} > 50\%$ . For actuation, a special procedure is used to provide a higher torque at startup.

The smoothing function dampens vibrations during a soft stop, which can arise with unstable loads, such as pump applications. With  $SmoothRate$ , you can adjust the rate of damping. When you preselect one of the two pumping applications, this function is automatically activated. It is only effective, however, if you also activate the  $U\text{-Stopramp}$  function.

Unlike the  $AutoStopProf$  function, which becomes active at the start of the soft stop ramp, the  $SmoothStop$  function acts on the lower section of the soft stop ramp.

**Kickstart (submenu)**

Some drives need an increased breakaway torque. This can be implemented with the Kickstart function.

PNU	Name	Value	Function	Def
13 [2013]	U-Kick [U-Kick 2]	60 to 90 %	Voltage level before start of actual ramp, for overcoming breakaway torque	75 %
14 [2014]	t-Kick [t-Kick 2]	10 to 40	Number of half-waves for which the kickstart voltage is to be applied	25
627 [2627]	Kickstart [Kickstart 2]	0 1	Off Activate kickstart	0

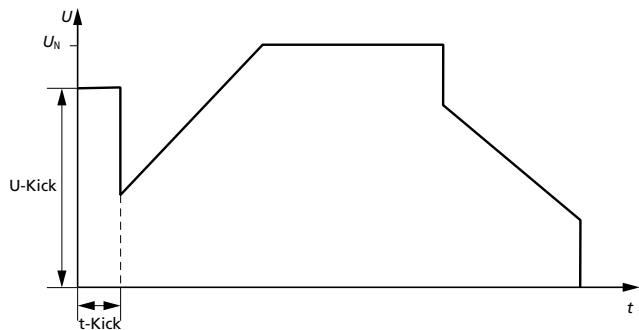

Figure 38: Kickstart

**Current (submenu)**

The current limiting functions prevent excessive current being drawn by the motor during startup. The voltage ramp is halted as long as the motor current exceeds the current limit. If the current limit is set too low, the motor cannot continue to accelerate.

To prevent overheating, the Current Limit function is disabled after the adjustable current limit time and the normal ramp either continued without regard to the set current limit or cut off with a fault message.

PNU	Name	Value	Function	Def
30 [2030]	I <sub>max</sub> -Start [I <sub>max</sub> -Start 2]	1.0 to 8.0 I <sub>e</sub>	Current limiting value at start in multiples of device's rated current	3.5 I <sub>e</sub>
31 [2031]	t-I <sub>max</sub> [t-I <sub>max</sub> 2]	5 to 255 s	Maximum time for which the starter maintains the current limit.	30 s
28 [2028]	I <sub>min</sub> [I <sub>min</sub> 2]	0.03 to 0.78 I <sub>e</sub>	Undercurrent limit value at startup in multiples of device's rated current	0.09 I <sub>e</sub>
29 [2029]	t-I <sub>min</sub> [t-I <sub>min</sub> 2]	5 to 255	Number of half-waves before an undercurrent message is triggered.	50
631 [2631]	Undercurrent [Undercurr.2]	0	Off	0
		1	Shut down with fault message	
628 [2628]	CurrentLimit [CurrentLim.2]	0	Continue ramp	1
		1	Shut down with fault message	

The behaviour after completion of the current limiting time (t-I<sub>max</sub>) is defined by parameter "CurrentLimit". If Continue Ramp is set, the soft start ramp is continued without further current limitation. Depending on the settings (high current limit, long ramp time, long current-limiting time), the protective elements may trip.

This setting may be appropriate to ensure that a motor starts under all circumstances. The whole drive should be dimensioned so as to prevent overheating. Alternatively, the end of the current limiting time can be used for tripping in case of a fault. This may be appropriate if such excessive loads are not expected to occur in normal operation.

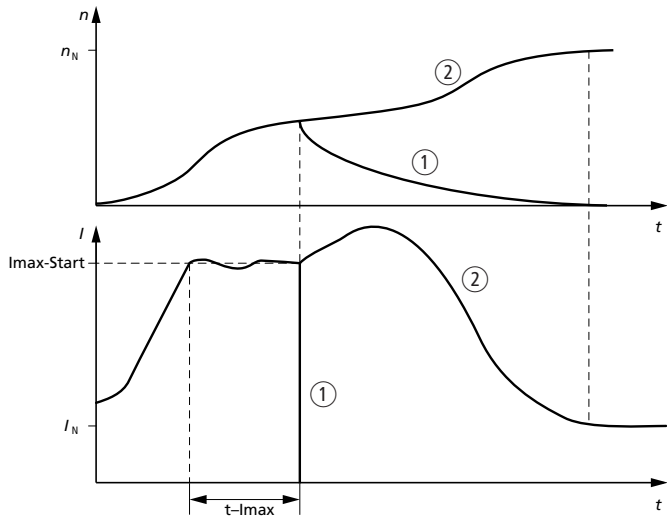

Figure 39: Current limit

- ① Shut down with fault message; motor spins down.
- ② Continue ramp function without current limit

The UnderCurrent function determines the load drop-off at the end of the ramp, when the motor runs at idle. This can be used, for example, to automatically switch the motor off when a drive belt breaks.

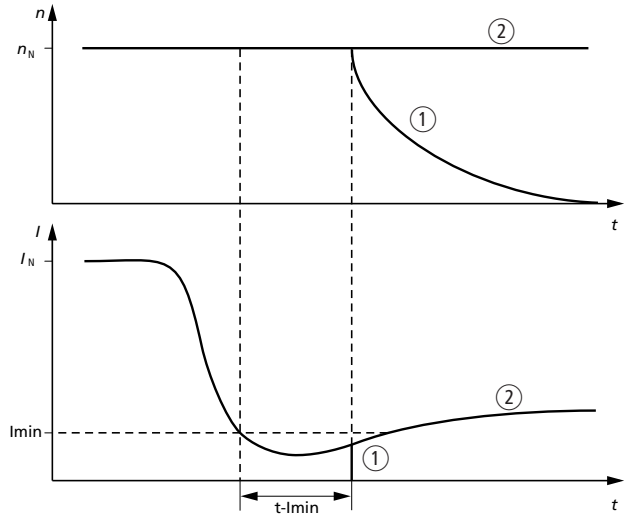

Figure 40: UnderCurrent

- ① Shut down with fault message; motor spins down.
- ② No shutdown on undercurrent; the drive continues to operate.

### cos-phi (p. f.) optimization (submenu)

The Protection parameter specifies when power factor (p. f.) optimization and the protection functions are applied.



If the system contains a bypass contactor or is connected in an in-delta configuration, the optimization functions must be disabled.



To ensure adherence to the EMC Directive, p. f. (cos-phi) optimization must be disabled.

PNU	Name	Value		Function	Def
15 [2015]	t-Dwell [t-Dwell 2]	1 s to 255 s		Time from reaching rated voltage to start of p. f. optimization	5 s
19	Rate	4 to 30		Speed with which p. f. optimization is performed. Important for low-slip motors with low mass inertia loads.	5
7 [2007]	Protection [Protection 2]	Bit 6	Bit 7		"Start+Bypass"
		0	0	No p. f. optimization; no PhaseLoss protection functions (0 dec)	
		1	0	No p. f. optimization; protection functions (continuous) (64 dec)	
		0	1	No p. f. optimization; protection functions at start (to top of ramp) Start+Bypass (128 dec)	
		1	1	P. f. optimization, protection functions (continuous) "Protect+Opti." (192 dec)	

The optimization phase starts after completion of the t-Dwell duration, which finishes after the end of the ramp. With p. f. optimization, the output voltage is reduced after completion of the t-Dwell duration. The voltage is reduced only to a level at which the motor speed does not collapse.

This reduces power dissipation in the motor. The savings are greatest with small motors and can be achieved only at partial load. If the motor is continuously working at full load, set the optimization rate to 30 (slow).

Motors with low rated slip and low mass inertia moment can exhibit unstable behaviour if p. f. optimization is active. In that case, increase the optimization factor until the motor exhibits a stable speed behaviour.

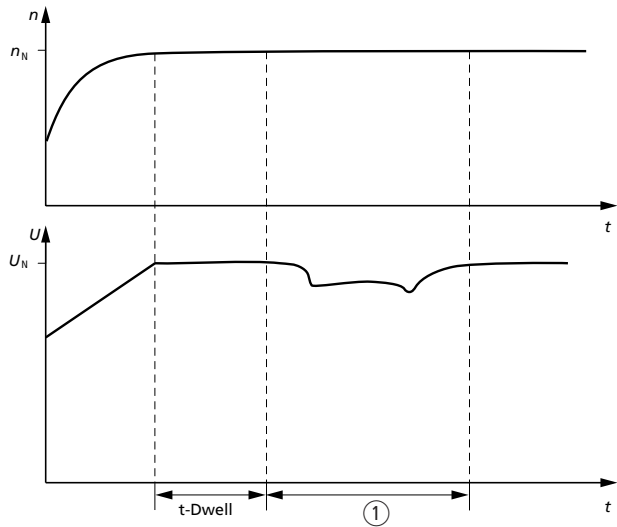

Figure 41: cos-phi (power factor)

① Time during which p. f. optimization is performed

### Terminal configuration

Each input and output of the DM4-340 series can be programmed individually, by programming a pointer (parameter) with the PNU of the parameter to be displayed.

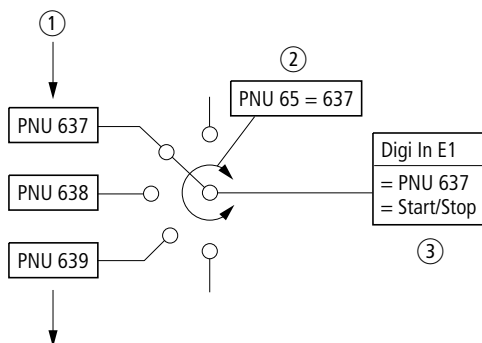

Figure 42: Allocating pointers

- ① Parameter list
- ② PNU 65 is the pointer for digital input E1
- ③ PNU 65 = 637: digital input E1 will enable/disable parameter 637

The control inputs/outputs are described in the following sections.



To disable a function, set its pointer to zero, (= PNU 0).

**Digital-In (submenu)**

PNU	Name	Value	Function	Def
65	E1-Pointer	0; 627 to 655	Digital input E1 is to affect the specified parameter.	637
653	E1-Logic	0	Low signal for activating the defined function	1
		1	High signal for activating the defined function	
67	E2-Pointer	0; 627 to 655	Digital input E2 is to affect the specified parameter.	633
654	E2-Logic	0	Low signal for activating the defined function	0
		1	High signal for activating the defined function	

PNU 637 controls the Start/Stop signal. If a signal is applied to terminal E1, a soft start is initiated. If no signal is applied, a soft stop is initiated. Before a soft start can be performed, PNU 40 must be set (high signal on terminal E2 at default settings or value 1 saved in PNU 40).

PNU 633 has the opposite effect to PNU 40. An inversion of the input signal (PNU 652 = 0) has the effect that input E2 acts like an Enable signal. When a signal is applied to terminal E2, the soft starter is enabled. If no signal is applied, the soft starter (the controller) is disabled and a soft start cannot be carried out. PNU 40 and PNU 633 are identical within the device. For technical reasons, PNU 40 cannot be linked to the inputs. PNU 633 can be used instead.

**Analog-In (submenu)**

The 0 to 10 V DC and 4 to 20 mA analog inputs fulfil two functions:

- In phase control operation mode, they can provide the setpoint for the desired output voltage.
- In starter operating mode, they can provide a monitoring message for a system variable. From a particular signalling threshold, you can set a user-defined bit. In this way, for example, the starter can be connected or disabled depending on the system status.

The 0 to 10 V DC and 4 to 20 mA analog inputs are independent from each other.

PNU	Name	Value	Function	Default
<b>0 to 10 V DC analog input</b>				
46	Ref1	0.0 to 9.9 V	Value of analog input Ref1	–
47	Ref1-Pointer	11 to 111; 2011 to 2035	Specifies the parameter to which analog input Ref1 transmits its value	0 = not used
48	Ref1 Level	0.0 to 10.0 V	Signalling threshold for the Ref1-Level bit	4.9 V
614	Ref1 Flag	0	Value at Ref1 below the signalling threshold in PNU 48	Status information
		1	Value at Ref1 above the signalling threshold in PNU 48	

PNU	Name	Value	Function	Default
<b>4 to 20 mA analog input</b>				
43	Ref2	0 to 20.4 mA	Value of analog input Ref2	–
45	Ref2-Pointer	11 to 111; 2011 to 2035	Specifies the parameter to which analog input Ref2 transmits its value	0 = not used
41	Ref2 Level	0.1 to 20.3 mA	Signalling threshold for the Ref2-Level bit	10.2 mA
615	Ref2 Flag	0	Value at Ref2 below the signalling threshold in PNU 41	Status information
		1	Value at Ref2 above the signalling threshold in PNU 41	

### Command (submenu)

PNU	Name	Value	Function	Default
<b>Command 1</b>				
40	Enable	0	Disable	1
		1	Enable	
627 [2627]	Kickstart [Kickstart 2]	0	Off	0
		1	Kickstart active	
628 [2628]	CurrentLimit [CurrentLim.2]	0	Continue ramp	1
		1	Shut down with fault message	
629 [2629]	OverLoad [OverLoad 2]	0	Off	1
		1	Overload monitoring active	
630 [2630]	OverCurrent [OverCurrent 2]	0	Continue	0
		1	Shut down at overcurrent	
631 [2631]	Undercurrent [Undercurr.2]	0	Off	0
		1	Shut down with fault message	
632 [2632]	Thermistor [Thermistor 2]	0	Off	0
		1	Thermistor active	

## Defining Parameters

PNU	Name	Value	Function	Default
<b>Command 2</b>				
634 [2634]	U-Stopramp [U-Stopramp2]	0	Off	0
		1	Voltage-controlled stop ramp	
635 [2635]	Invert Ref0 [InvertRef0 2]	0	No reference inversion	1
		1	Invert reference	
636	OptionStart	0	Stop signal applied	Status information
		1	Start signal applied	
637	TerminlStart	0	Stop signal applied	Status information
		1	Start signal applied	
638	Run relay	0	Off	Status information
		1	Enable signal for activating main contactor	
639	PAR1/PAR2	0	Parameter set 1 active	0
		1	Parameter set 2 active	
640	Tmp t-Stop=0	0	Off	0
		1	Overwrite soft stop ramp	
<b>From software version PNU 99 = 53.12</b>				
671 [2671]	t-Start = 0 [t-Start = 0 2]	0	No	0
		1	On; ignore soft start time and work with time zero	

PNU	Name	Value	Function	Default
<b>Command 3</b>				
641	Currently not used			1
642	Currently not used			1
643	Set I <sub>max</sub>	0	Off	0
		1	Simulate operation at current limit	
644	ExtFault	0	Off	0
		1	External fault has occurred	
645 [2645]	AutoEndStop [AutoEndStop2]	0	Off	0
		1	Automatic ramp end on soft stop	
646 [2646]	AutoStopProf [AutoStopPrf2]	0	Off	0
		1	Match soft stop profile to load	
647 [2647]	AutoEndStart [AutoEndStrt2]	0	Off	0
		1	Automatic ramp end on soft start	
648 [2648]	AutoU-Start [AutoU-Start2]	0	Off	0
		1	On	
655 [2655]	AutoBypass [AutoBypass2]	0	Off	1
		1	On	

When PNU 655 = 1, the DM4 automatically recognizes a connected bypass and sets PNU 7 to Start+Bypass.

When PNU 657 is 1, the set soft start time t-Start is not taken into account and the start is carried out with a time of zero. This function should be used if the soft starter is used for stopping a motor cascade connected to the soft starter through bypass contactors. The time stored in parameter 12 t-Start remains unchanged.

**PhaseControl (submenu)**

To set the output voltage, specify the control angle (the smaller the angle, the higher the voltage). The relationship between angle and output voltage is non-linear. The Invert Ref0 switch specifies whether the maximum voltage will be reached at setpoint zero or at maximum setpoint (value = 0 or 1).

As for Soft starter mode (Standard and In-delta), terminal E2 (PNU 40 = 1) must carry an Enable signal and terminal E1 (Start/Stop) a control signal. When terminal E1 carries a High signal, the specified setpoint value is active.



To ensure adherence to the EMC Directive, an external RFI filter is required in regulator operation. Because the filter required depends on the type of load (resistive, inductive, resistive/inductive), responsibility for choosing the appropriate filter must rest with the user.

PNU	Name	Value	Function	Default
<b>Open-loop and closed-loop control modes</b>				
109	KI	0 to 50	I-component of the voltage regulator	10
110	Umax	0 to 100	Maximum output voltage	10
635 [2635]	Invert Ref0 [InvertRef0 2]	0	No inversion; Max In = Max Out	0
		1	Signal inversion active; Max In = Min Out	
105	Ref0-Pointer	0 to 111	Pointer to parameter to deliver setpoint	46
111	UserParametr	0 to 255	User-defined value	0
<b>In addition, for closed-loop control mode</b>				
106	FeedBackPntr	0 to 111	Contains the PNU of the parameter that delivers the actual value	26
107	KP (Mul)	1 to 255	P-component of the closed-loop voltage controller (gain)	37
108	KP (Div)	1 to 255	P-component of the closed-loop voltage controller (divide)	7

In addition to open-loop control mode, an actual value is returned in Closed-Loop Control mode. The actual value is compared with the setpoint. If the values are different, the output voltage is adjusted.

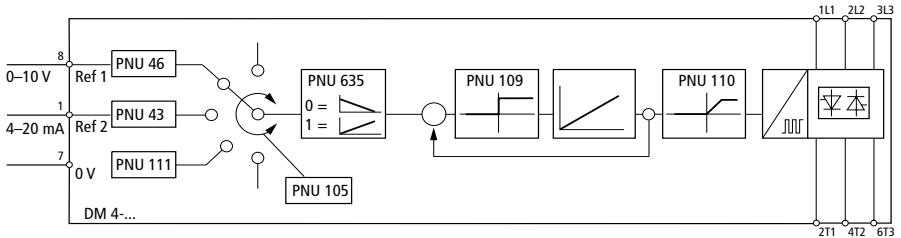

Figure 43: Open-loop voltage controller

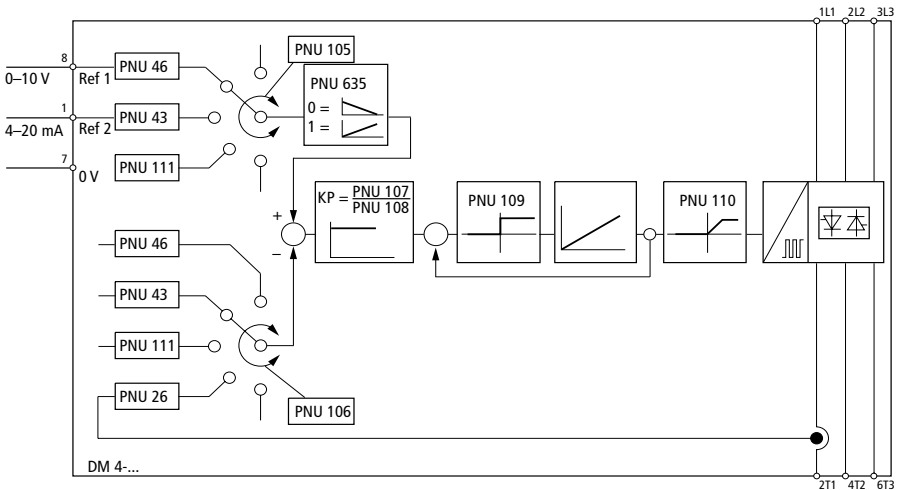

Figure 44: Closed-loop voltage controller

## Defining Parameters

## Display functions

The Indications main menu contains seven submenus.

## Device Data (submenu)

PNU	Name	Value	Function	Default
9	Address	1 to 99	Device address for bus and interface operation	1
93	Drive Type	10	Drive type code	–
200	SoftwareType	53BDM 434050000	Manufacturer's code for software used	–
99	Software Ver		Manufacturer's code for internal software version	Device-dependent
201	Software Dat		Manufacturer's code for the internal software creation date	Device-dependent
24	$I_e$	5 to 2000 A	Rated operating current of the soft starter	Device-dependent

## Status (submenu)

PNU	Name	Value	Function
<b>Status 1</b>			
600	Stopped	0	Motor running
		1	Motor stopped
601	Ramp	0	Soft starter not in ramp function
		1	Soft starter working in ramp function
602	Imax-Limit	0	Current limit from PNU 30 reached
		1	Output current below current limit specified in PNU 30
603	Top of Ramp	0	Soft starter working in ramp function or is in Stop
		1	Top of ramp reached; 100 % output voltage

PNU	Name	Value	Function
604	t-Dwell off	0	Dwell time since Top of Ramp incomplete
		1	Dwell time since Top of Ramp completed; drive can perform p. f. optimization
605	Umax reached	0	Thyristors working with phase control
		1	Thyristors working at maximum delay angle
606	Optimising	0	P. f. optimization not active
		1	P. f. optimization active
607	Stop-Ramp	0	Soft starter not in stop ramp mode
		1	Soft starter working in stop ramp mode
<b>Status 2</b>			
608	Alarm	0	Normal operation
		1	Soft starter malfunction
609	Overload>0	0	Overload function is zero
		1	Overload function was activated.
610	Stalling	0	Motor is working correctly
		1	Motor wants to stall and is being automatically corrected by the soft starter. May occur with p. f. optimization.
611	Full Load	0	P. f. optimization can be activated
		1	Due to high load, p. f. optimization cannot be activated, even if selected. Motor always running at 100 % voltage.
612	Noise	0	Soft starter working correctly
		1	The soft starter has identified excessive external interference voltage
614	Ref1 Flag	0	Value at Ref1 below the signalling threshold in PNU 48
		1	Value at Ref1 above the signalling threshold in PNU 48
615	Ref2 Flag	0	Value at Ref2 below the signalling threshold in PNU 46
		1	Value at Ref2 above the signalling threshold in PNU 46

## Defining Parameters

PNU	Name	Value	Function
<b>From software version PNU 99 = 53.12</b>			
672	StartPause	0 = no	Cooling time has expired
		1 = wait	Cooling time still running
<b>Status 3</b>			
616	Relay K1	0	Relay not energized
		1	Relay energized
617	Relay K2	0	Relay not energized
		1	Relay energized
618	Relay K3	0	Relay not energized
		1	Relay energized
619	Relay K4	0	Relay not energized
		1	Relay energized
620	Digi-In. E1	0	Input signal is Low (0)
		1	Input signal is High (1)
621	Digi-In. E2	0	Input signal is Low (0)
		1	Input signal is High (1)
<b>Status 4</b>			
622	50/60 Hz	0	50 Hz
		1	60 Hz
623	Rotation	0	Clockwise rotation at startup
		1	Anticlockwise rotation at startup
624	OverCurr.LIM	0	Off
		1	Overcurrent reached and still flowing
625	UnderCurr. LIM	0	Off
		1	Undercurrent reached and still flowing
626	Thermis.LIM	0	Off
		1	A thermistor message is being sent

If you have activated the start monitoring time (see section "Heat sink", page 125), parameter StartPause (PNU 672) indicates whether a further start is permissible or whether the waiting time to the next start is still running.

### Display (submenu)

Many values are determined and monitored during soft starter operation. This information can be displayed on the LCD keypad, or output to one of the analog outputs for display.

PNU	Name	Value	Function	Unit/representation
20	cos-phi ref	0 to 146°	Optimum p. f. of the motor (calculated)	Angle
21	cos-phi	0 to 146°	Current p. f. of the motor (measured)	Angle
22	Delay angle	0 to 146°	Time during which the thyristor is shut down	Angle
23	Max.Delay	17 to 146°	Maximum delay angle during the optimization phase	Angle
26	LoadCurrent	0 to $8 \times I_e$	Output current (per phase, independent from the connection type (Standard/ In-delta)	Amps
27	PeakCurrent	0 to $8 \times I_e$	Maximum current during the last start	Amps
36	Overload-Sum	0 to 100 %	Current $I^2t$ value of the overload integrator in % of the permissible device limit value	%
37	T-Heatsink	0 to 255	When the temperature rises, the displayed value jumps from 20 to 200.	–
46	Ref1	0 to 10 V	Current actual value at Ref1	–
43	Ref2	0 to 20 mA	Current actual value at Ref2	–
42	ThermistorVal	0 to 255	Indicates the actual value of the connected thermistor as a relative value. When the temperature rises, the displayed value usually jumps from < 20 to > 200.	–

## Defining Parameters

PNU	Name	Value	Function	Unit/representation
55	Load	0.0 to $8.0 \times I_e$	Current device load in multiples of the rated current	–
56	PeakLoad	0.0 to $8.0 \times I_e$	Peak device load in multiples of the rated current	–

## Analog-Out (submenu)

PNU	Name	Value	Function	Default
<b>Analog Out 1</b>				
49	AnOut1Pntr	20 to 111	Specifies a PNU to be transmitted to analog output 1. Output signal: 0 to 10 V DC, 10 mA	26 = load current
<b>Analog Out 1</b>				
50	AnOut2Pntr	20 to 111	Specifies a PNU to be transmitted to analog output 2. Output signal: 0 to 10 V DC, 10 mA	22 = delay angle

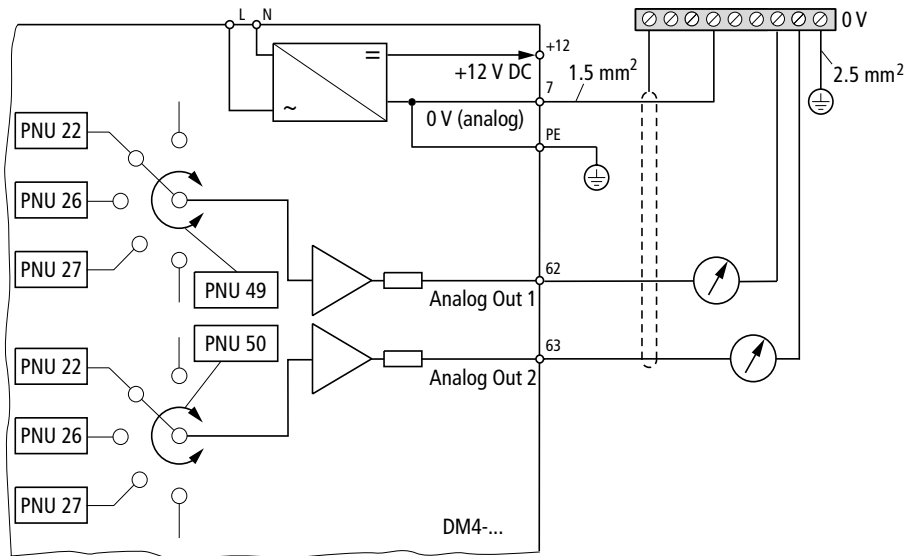

Figure 45: Analog output with PNUs

Through the analog outputs, you can view the following parameters:

PNU	Name	Value	Function	Output voltage 10 V
20	cos-phi ref	0 to 146°	Optimum p. f. of the motor (calculated)	8.16 ms <sup>1)</sup>
21	cos-phi	0 to 146°	Current p. f. of the motor (measured)	8.16 ms <sup>1)</sup>
22	Delay angle	0 to 146°	Time during which the thyristor is shut down.	8.16 ms <sup>1)</sup>
23	Max.Delay	17 to 146°	Maximum delay angle during the optimization phase	8.16 ms <sup>1)</sup>
26	LoadCurrent	0 to 8 × I <sub>e</sub>	Output current (per phase, independent from the connection type (Standard/ In-delta)	8 × I <sub>e</sub> (PNU 24) Rated current = 1.25 V
27	PeakCurrent	0 to 8 × I <sub>e</sub>	Maximum current during the last start	8 × I <sub>e</sub> (PNU 24) Rated current = 1.25 V

## Defining Parameters

PNU	Name	Value	Function	Output voltage 10 V
36	Overload-Sum	0 to 100 %	Current $I^2t$ value of the overload integrator in % of the permissible device limit value	100 %
37	T-Heatsink	0 to 255	When the temperature rises, the displayed value jumps from < 20 to > 200.	255
46	Ref1	0 to 9.9 V	Current actual value at Ref1	10 V
43	Ref2	0 to 20.4 mA	Current actual value at Ref2	20 mA
42	ThermistorVal	0 to 255	Indicates the actual value of the connected thermistor as a relative value. When the temperature rises or in the event of a wire break the displayed value usually jumps from < 20 to > 200.	255
111	UserParametr	0 to 255	User-defined value	255

- 1) The delay angles are displayed according to the mains frequency.

At 50 Hz, the actual angle is calculated as follows:

$$\alpha = 180^\circ \times \frac{8.16 \text{ ms}}{10 \text{ ms}} \times \frac{\text{Output voltage in V}}{10 \text{ V}} = \frac{14.688^\circ}{\text{V}} \times \text{Output voltage in V}$$

At 60 Hz, the actual angle is calculated as follows:

$$\alpha = 180^\circ \times \frac{8.16 \text{ ms}}{8.16 \text{ ms}} \times \frac{\text{Output voltage in V}}{10 \text{ V}} = \frac{18^\circ}{\text{V}} \times \text{Output voltage in V}$$

---

**Monitoring functions**

The Monitoring main menu contains seven submenus.

Four make contacts and several protection functions are available for monitoring the soft starter.

You can assign various functions to the relay contacts. This is done in the same way as for the digital inputs. A pointer is used to specify a parameter to which the relay is to respond. The Output Logic switch can be used to specify whether the relay is to energize with the respective bit in High or Low state.

Appropriate parameters are the four status parameters and parts of the command.

With the LCD keypad, you can view current fault messages directly on the display. The trip register provides information about past faults, which can be used for determining the source of a problem.

The motor protection function provides optimum motor protection, since a tripping class above Class 15 is reached at heavy starting duty and/or frequent starts. Normal overload relays are not suitable for trip classes above 15. Here, special-purpose or electronic relays are required. The series DM4-340 soft starters can perform this function.

## Defining Parameters



This function has no thermal memory. When the controller power supply is switched off, the calculated  $I^2t$  value is reset to zero.



The required motor rating must be determined from the expected load. At heavy starting duty with a tripping class higher than 15, a standard motor may not be able to deliver its full rated power. Under heavy starting conditions, contact the motor manufacturer to establish the motor's maximum permissible power.

## Relay output K1 (submenu)

PNU	Name	Value	Function	Default
57	K1-Pointer	0; 600 to 673	Specifies the parameter to be used for controlling relay K1.	638 (Run Relay)
649	K1-Logic	0	Low signal triggers switching.	1
		1	High signal triggers switching.	–
71	K1-delaytime	20 to 800 ms	Delay time for Run, TOR and Alarm	160 ms

The K1-Pointer specifies the status bit by which the relay is controlled. In addition, you can use the K1-Logic to specify whether the relay switches at High or at Low signal (make contact or break contact function).

**Delay time (K1-Time) in submenu Relay K1**

A delay time (K1-Time) can be programmed for three status parameters. Run Relay, TOR and Alarm (PNU 638, PNU 603, PNU 608).

If a time other than zero has been programmed, the soft starter responds with deceleration, irrespective of the relay to which these signals are programmed. If one of these status parameters is programmed to a relay, the relay also switches with a corresponding delay (analogous to the status parameters). This provides a simple way for bypass contactors to be safely switched off in AC operation or to control the mains contactor through the soft starter. The number of required external switching operations can therefore be reduced.

Effect on the Run Relay status bit (PNU 638):

When relay K1 is energized, the power section begins after the time set with K1-delaytime. Only then do the monitoring functions become active. With the Run Relay function, the mains contactor can therefore be disconnected from the device without triggering a fault (phase failure). The control sequence is then:

- Apply soft start command.
- Relay K1 energizes.
- Relay K1 actuates the mains contactor.
- After the time specified in PNU 71, the start procedure and phase monitoring begin.

Without this delay, phase monitoring would be initiated immediately by the start command and the soft starter would shut down with a fault message before the mains contactor is energized.

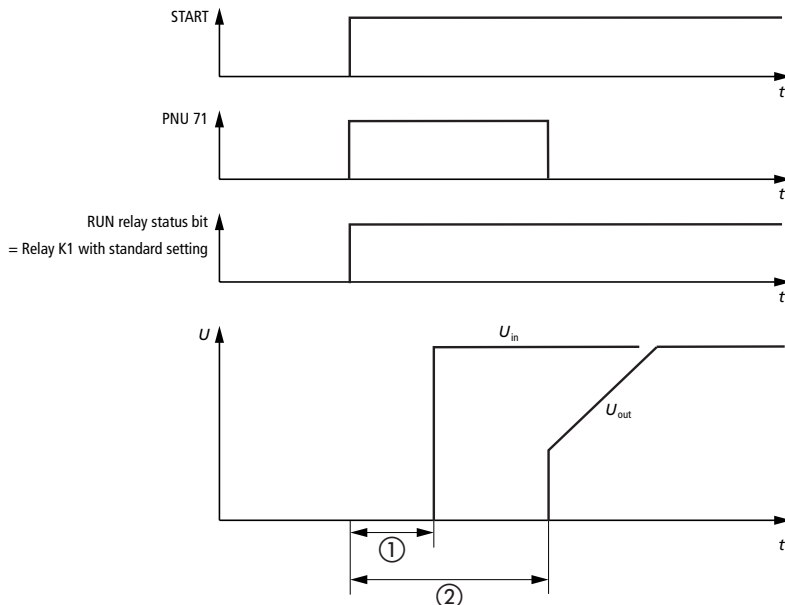

Figure 46: Parameter K1 with Run

- ① Time before the mains contactor is switched and voltage is applied to the soft starter's input
- ② PNU 71 = K1-delaytime  
Delay between energizing K1 and start of the first thyristor firing

Effect on status bit TOR (PNU 603):

When the soft stop command is issued, the TOR bit drops to Low. The actual soft stop is initiated only after completion of K1-delaytime. This ensures that current flows to the soft starter before the ramp function is initiated.

If the bypass contactor is relatively slowly to drop off, the ramp can already have started while the bypass contactor is still closed. In this case, the soft starter would be supplied from the secondary side, which could lead to soft starter malfunction. The control sequence is then:

- Apply soft stop command
- K1-delaytime expires
- Soft stop ramp is initiated

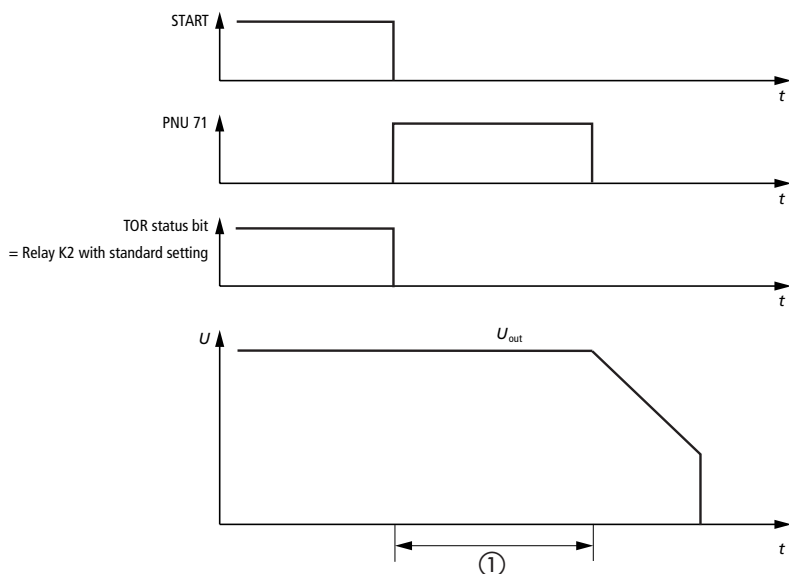

Figure 47: Parameter K1 with TOR

- ① PNU 71 = K1-delaytime  
time between deactivation of TOR message and start of soft stop ramp

**Defining Parameters**

Set parameter K1-delaytime to a time greater than or equal to the time which the bypass needs to open (total time from the TOR relay of the DM4 opening to the bypass being open). If this circuit contains several coupling relays or PLCs, times clearly in excess of the default setting of 160 ms may occur. If too short a time has been set, the bypass switches only after the soft stop ramp has started, which can cause strong current peaks.

Effect on Alarm status bit (PNU 608):

When a fault occurs, the soft starter is disabled. If a K1-delaytime is programmed, the shutdown procedure is as follows:

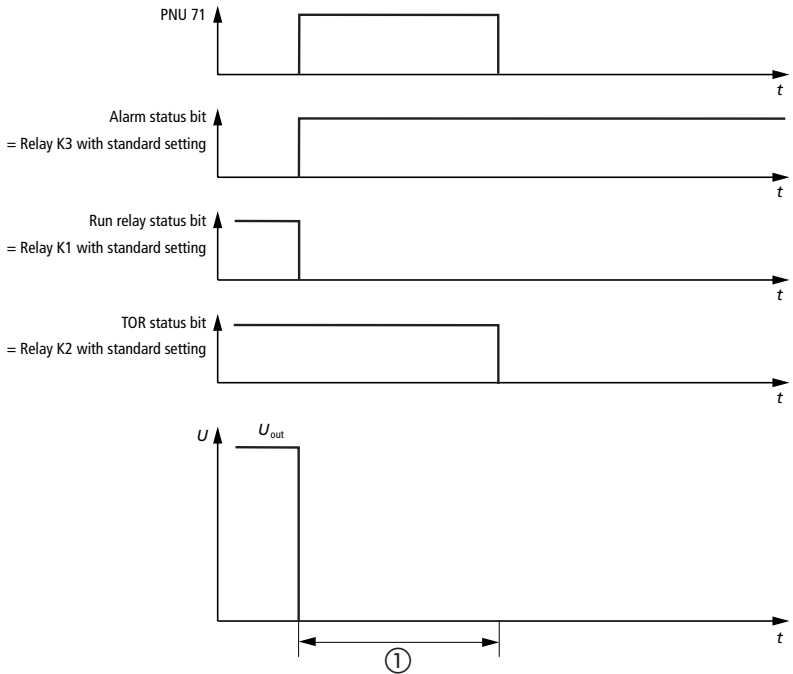

Figure 48: Parameter K1 with Alarm

- ① PNU 71 = K1-delaytime  
Time from fault to shutdown of the TOR status bit

## Defining Parameters

When the Alarm bit is set, the Run Relay bit is reset at the same time and the power section is shut down. The K1-delaytime then expires and the TOR bit is reset. The control sequence is then:

- Alarm message
- Disable power section
- Set alarm flag
- Delete Run status bit
- K1-delaytime expires
- Delete TOR status bit

## Relay outputs K2 to K4 (submenus)

PNU	Name	Value	Function	Def
<b>Relay output K2</b>				
59	K2-Pointer	0; 600 to 655	Specifies the parameter from which a bit is to be used to control relay K2.	603 (Top of Ramp)
650	K2-Logic	0	Low signal triggers switching.	1
		1	High signal triggers switching.	
<b>Relay output K3</b>				
61	K3-Pointer	0; 600 to 655	Specifies the parameter from which a bit is to be used to control relay K3.	608 (Alarm)
651	K3-Logic	0	Low signal triggers switching.	1
		1	High signal triggers switching.	
<b>Relay output K4</b>				
63	K4-Pointer	0; 600 to 655	Specifies the parameter from which a bit is to be used to control relay K4.	609 (Overload > 0)
652	K4-Logic	0	Low signal triggers switching.	1
		1	High signal triggers switching.	

**Heatsink (submenu)**

The temperature value is not in degrees Celsius, but an internal representation. Display values under 20 represent normal temperatures.

PNU	Name	Value	Function	Def
37	T-Heatsink	0 to 255	When the temperature rises, the displayed value jumps from 20 to 200.	–
44	Temp.Limit	0 to 255	Switching threshold for temperature fault message	250
<b>From software version PNU 99 = 53.12</b>				
673	StartMonitor	0	Off	1
		1	On – After start, wait for time t-Pause before the next start.	
116	t-Pause	0 to 3825 s	Cooling time before next start	0

Temp.Limit specifies the heatsink temperature at which a fault message is generated.

With parameter t-Pause, you define a monitoring time (in steps of 15 s), which must expire before the next start can take place. This prevents that the soft starter is thermally overloaded through frequent starting. Status word 2, PNU 613 (StartPause) indicates the current state of the monitor.

A new Start signal is recognized only after a change from "Off" to "On" (restart interlock after expiry of waiting time).

**Thermistor (submenu)**

The thermistor input is suitable for connecting thermistors or temperature switches (break contacts to IEC 60034-11). With it, motor temperature can be determined and included in the soft starter monitoring function. The default setting for this input is Off (thermistor monitoring disabled).

PNU	Name	Value	Function	Unit/ indication
42	ThermistorVal	0 to 255	Indicates the actual value of the connected thermistor as a relative value. When the temperature rises, the displayed value usually jumps from < 20 to > 200.	–
626	Thermis.LIM	0	Off	No
		1	Limit value exceeded, device switches off with fault.	Too hot
632	Thermistor	0	Off	0
		1	Thermistor protection active	



The temperature value is not in degrees Celsius, but an internal representation. Display values under 20 represent normal temperatures.

If the internally specified signalling threshold is exceeded, the DM4-340 shuts down with a fault message (Motor overtemperature). When the fault condition is rectified, the soft starter can be restarted after a reset (see section "Fault messages and remedy" on page 154).

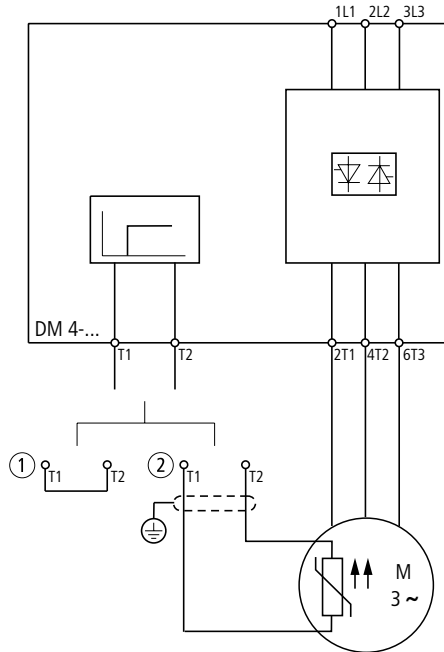

Figure 49: Thermistor connection

- ① No thermistor connected, insert jumper or set PNU 632 = 0 (default setting!)
- ② With thermistor

## Defining Parameters

## Motorprotect (submenu)

PNU	Name	Value	Function	Def
32 [2032]	OverCurr.max [OverCurr-Max2]	1.0 to 5.0 $I_e$	Limit value for overcurrent shutdown after top of ramp	3.12 $I_e$
33 [2033]	t-Overcurr. [t-Overcurr2]	5 to 255	Number of half waves by which the overcurrent limit value must be exceeded before an overcurrent shutdown is triggered. OverCurrent must be set (PNU 630 = 1) for a shutdown to take place.	100
630 [2630]	OverCurrent [OverCurrent 2]	0	OverCurrent function disabled	1
		1	Shut down at overcurrent	
34 [2034]	Overload max [OverloadMax2]	0.6 to 2.0 $I_e$	Overload limit for the motor after top of ramp in multiples of the device rated current	1.09 $I_e$
35 [2035]	t-Overload [t-Overload 2]	10 to 140	Dimensionless factor. Determines the time for which a drive must be overloaded before an overload shutdown takes place. This function is always active.	140
36	Overload-Sum	0 to 100 %	Current $I^2t$ value of the overload integrator in % of the permissible device limit value	
629 [2629]	Overload [Overload 2]	0	Off	1
		1	Shut down with fault message	

The overcurrent function provides blocking protection. If the current rises significantly above the motor's rated current during operation, the machine is – as a rule – blocked. The soft starter recognizes this condition and shuts the motor down before the motor suffers excessive thermal overload.



Do not set this value too low, otherwise the protective function could trigger on a permissible overload.

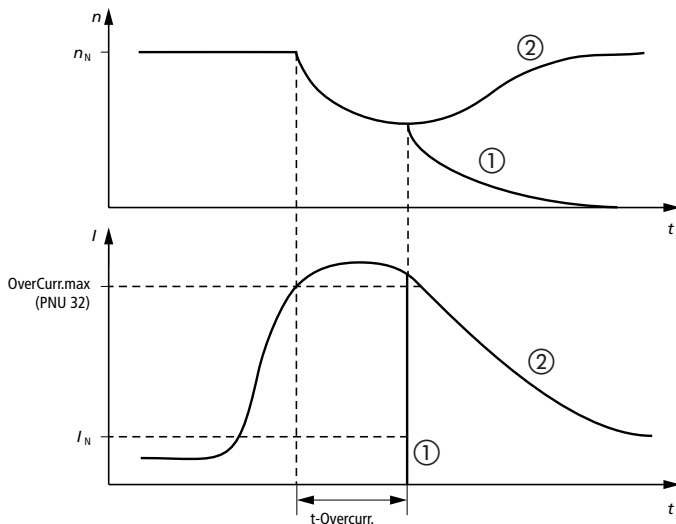

Figure 50: OverCurrent

- ① Shut down with fault message; motor spins down.
- ② Continue operation as long as the soft starter's thermal monitoring function does not respond.

With the motor protection function, the temperature of self-ventilated three-phase induction motors can be monitored. The technical data of the motor are defined with the current limit values.

Provided the motor data is entered correctly, the series DM4-340 soft starter performs the function of the overload relay. The calculated values are maintained as long as the controller supply voltage is applied.



This function has no thermal memory: when the controller power supply is switched off, the calculated  $I^2t$  value is reset to zero.



To ensure that the motor protection function works correctly, the controller supply voltage should not be interrupted between starts. The power supply of terminals 1L1, 2L2 and 3L3 can be switched off between two starts. This has no effect on the motor protection function.

PNU 34 and PNU 35 determine the trip characteristics.

Example:

PNU 34 = Rated motor current  $\times 1.1$

PNU 35 = read off graph below

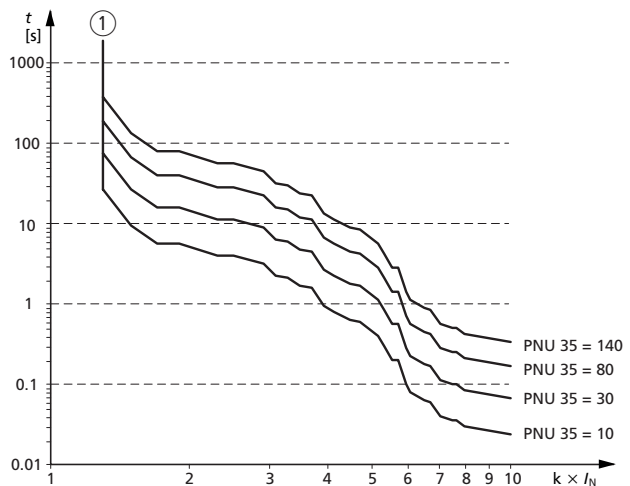

Figure 51: Overload reaction

① Limit curve, above which a shutdown is tripped.

### Viewing fault messages

The Trips main menu does not contain any submenus. The parameters are displayed directly.

The last five trips are saved in the soft starter analogous to a stack register. When a new fault occurs, the oldest trip is discarded from the stack.

You can view the fault messages on the LCD keypad or query them through the interface modules.

PNU	Name	Value	Function
72	Trip sensitivity	1 to 15	Trip sensitivity
161	TripHistory1	1 to 15	Stores the specified fault.
162	TripHistory2		
163	TripHistory3		
164	TripHistory4		
165	TripHistory5		

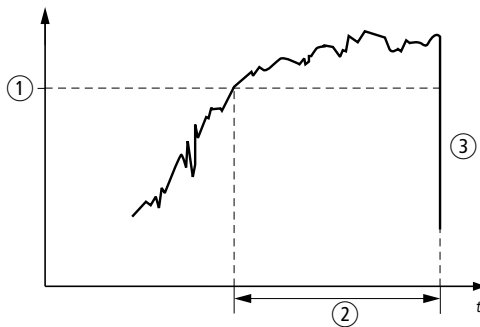

Figure 52: Trip sensitivity

- ① Response threshold for recognition of a fault condition; factory preset.
- ② PNU 72: Trip-Sensitivity; specifies the time at which a recognized fault is reported.
- ③ Shutdown after expiry of the tolerance time (PNU 72)

## Defining Parameters

The trip sensitivity defines the time that the soft starter waits before an identified fault condition is reported. This is useful for smoothing information affected by noise.

- 1 = fastest response
- 15 = slowest response



If no LCD keypad or interface is connected to the soft starter, the LEDs on the front panel show a diagnostics signal (see section "Diagnostics" page 153).

## Fault codes

Fault number	Message	Fault
0	No Trip	No trip.
1	PhaseLoss	One or more phases missing on mains side.
2	OverTemp.	Soft starter's heatsink overheated.
3	Thyristor	Fault in thyristor or its control circuit.
4	Firing	Thyristor has not fired.
5	Thyristor	Error in control signal.
6	Thyristor	Error in control signal.
7	Thyristor	Fault in thyristor monitoring.
8	Thyristor	Motor phase missing or thyristor always conducting.
9	Thyristor	Fault in thyristor monitoring.
10	Thy Shorted	Thyristor is always conducting.
11	UnderCurrent	Not enough current flowing after top of ramp.
12	Current limit	Drive at set current limit for too long at start.
13	Overload	Motor protection function has responded after startup.
14	OverCurr.max	Max. overcurrent exceeded.
15	Thermistor	Motor thermistor has tripped.
16		Default factory setting, no fault

**Reset fault message/register**

The trip register cannot be deleted. It can only be overwritten with new trips. New trips are entered under TripHistory1. All other errors move one place down, the last one being pushed off the list and thereby deleted from the register.

When a fault occurs, the soft starter is disabled. To restart it, you must reset and reissue the start command. If the old fault is still pending, the soft starter returns directly to the fault condition and generates a new fault message.

**Parameters not in the  
menu structure**

For communication modules and similar components, there are further parameters which cannot be accessed through the menu. The PNU 135 and PNU 150 can only be read and written to with the network modules or the PC software. The content of these two parameters consists of the parameters already described.

PNU 633 always has the opposite state of PNU 40. For device-specific reasons, PNU 633 is available instead of PNU 40 in the list of possible parameters for the digital inputs.

**Network operation  
(from software version PNU 99 = 53.12)**

If the DM4 is operated with a network option, two data channels to the device are established, one for process data and one for parameter data. The influence each of these channels can have on the device is specified with parameter PNU 001 (Start commands).

The command is issued depending on the option used (transparent or according to DRIVECOM profile). For further details, see the documentation of the corresponding network module. In addition, command PNU 135, bit 13 must be set to "1" to enable control through the bus (= UnlockBus). If bit 13 is set to 0, no bus-transmitted control commands are accepted.

### Parameter data channel

The use of the parameter channel is described in the network module descriptions. All parameters of the DM4 can be read- and write-accessed. For the data formats and value ranges, see the parameter table in the appendix from page 198.

### Process data channel

A command and a setpoint value are transmitted from the controller to the DM4. The command corresponds to parameter PNU 135 and can control the starter only if parameter PNU 001 (Start commands) is set to 3. The setpoint value in the process data channel is only relevant in the Controller and Regulator (PNU 006) control modes. The transmitted value is written to parameter PNU 111. If this value is to be used as the setpoint value, parameter PNU 105 (Ref0 indicator) must be set to 111. By default, PNU 105 is configured as analog input 1.

A status word and the present actual current value are transmitted from the DM4 to the PLC. The status word corresponds to parameter PNU 150 and is transmitted in every control mode. The transmitted actual current value corresponds to the value in parameter PNU 055 \* 32, i. e. the value range of PNU 55 (0.0 to 8.0) is transmitted as a byte value without decimal places in the range 0 to 255.

Example: PNU 55 = 1.0 is transmitted as 32.

PNU	Name	Value	Function
135	ComCommandW	Bit 3 = 0 = 1	Softstart (RUN) Softstop (Stop)
		Bit 9 = 0 = 1	Enable Disable
		Bit 12 = 0 = 1	PAR1 selected PAR2 selected
		Bit 13 = 0 = 1	LockBus UnLockBus
150	ComStatusW	Bit 0 = 0 = 1	PAR1 active PAR2 active
		Bit 1 = 0 = 1	Motor Running Motor stopped
		Bit 2 = 0 = 1	Below the current limit – Current limit from PNU 30 reached
		Bit 3 = 0 = 1	Starter in ramp function or stop TOR
		Bit 4 = 0 = 1	TOR Starter in ramp function or stop
		Bit 6 = 0 = 1	Running Stopped
		Bit 7 = 0 = 1	Enabled Disabled
		Bit 8 to 11 = 0 = 3 = 6 = 7 = 8 = 15	Device status Initializing Disabled (PNU 40 = 0) Enabled (PNU 40 = 1) Warning issued. Error DM4 switched off (for external interface module supply only)
		Bit 14 = 0 = 1	Clockwise rotating field Anticlockwise rotating field
		Bit 15 = 0 = 1	Not ready for operation Ready for operation
633	Not Enable	0	Device not disabled = Enable
		1	Device disabled



## 4 Mounting/Installation

### Scope of delivery

When you first receive the soft starter, check that the delivery is complete and correct. If any items are missing or faulty, please contact your sales outlet.

Package contents	Quantity
DM4-340 units	1
Installation instructions (AWA)	1
CD with device descriptions	1

### Installing in a control cabinet



During assembly, please consider the weight and dimensions of the soft starter. Use appropriate handling and lifting equipment (lifting trolley and/or crane for heavier weights) and tools. Improper handling and the use of incorrect tools can damage the soft starter.

**Caution!**

Soft starters are designed for use only as built-in devices. Take appropriate preventive measures in case of

- contaminated cooling air, dust, fluff and grease, as these can cause short-circuits on the printed circuit boards (install filters, use separate ventilation air supply);
- corrosive gases, which can etch tracks on printed circuit boards (install filters, use separate ventilation air supply)
- contaminated filters, as they can cause overheating (clean the filters regularly).

To avoid overheating,

- ensure a free flow of cooling air, both to and from the device;
- Do not install other equipment that generates a lot of heat close to the soft starter.
- ensure that the specified clearance of above and below the soft starter is maintained, since the temperature of the cooling air can otherwise rise to inadmissible values, causing the soft starter to shut down.



The DM4 series soft starter requires a clearance of 25 mm at the front. Above and below the device, the clearance must be 75 mm for models up to 350 A or 200 mm for models over 350 A; to each side, 30 mm are required. For device over 350 A, a larger side clearance is required if the enclosure doors are to be opened 90°. A clearance of 75 mm is then necessary to the left side.

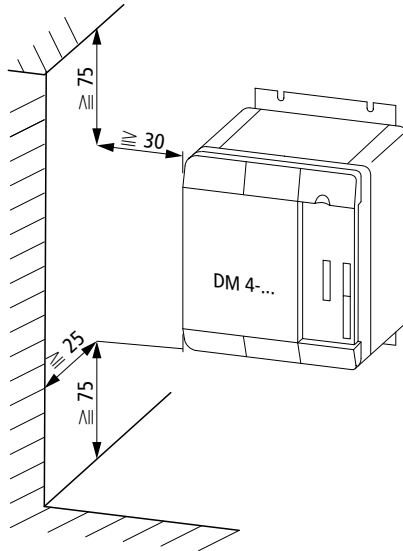

Figure 53: Installation clearances, DM4-340-7K5 to DM4-340-200K

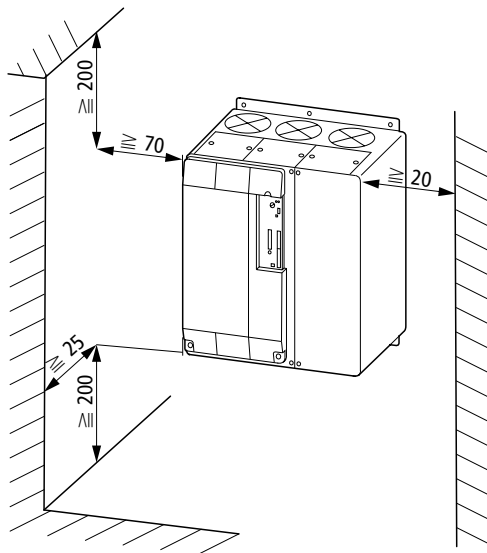

Figure 54: Installation clearances, DM4-340-250K to DM4-340-500K



If you will use the soft starter in environments in which it is exposed to continuous vibration or impacts, consider fitting vibration dampers.

### Possible mounting positions

The greatest permissible angle of inclination for all soft starters is  $30^\circ$ .

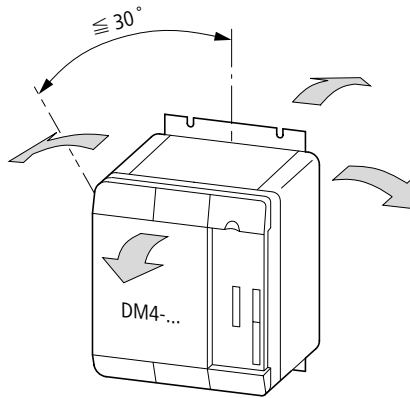

Figure 55: Inclination, DM4-340-7K5 to DM4-340-500K

Using M6 screws, mount the soft starter on the cabinet wall (mounting plate), so that the control signal terminals point forward.

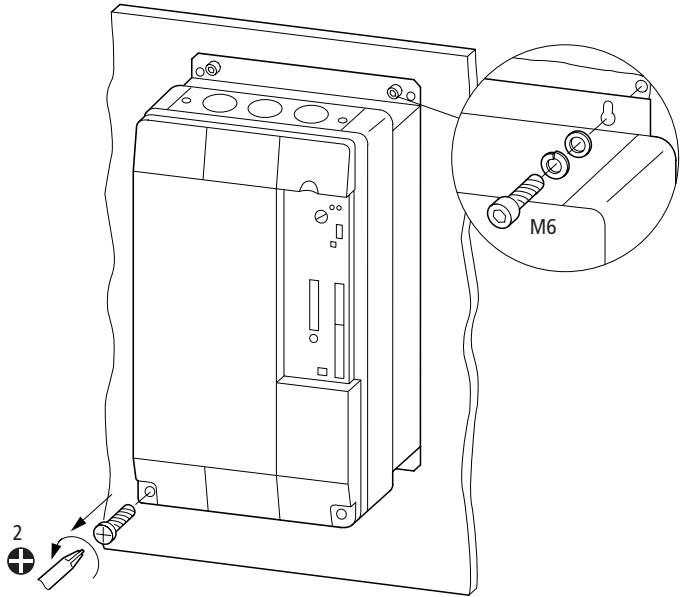

Figure 56: Installation on mounting plate, DM4-340-7K5 to DM4-340-200K

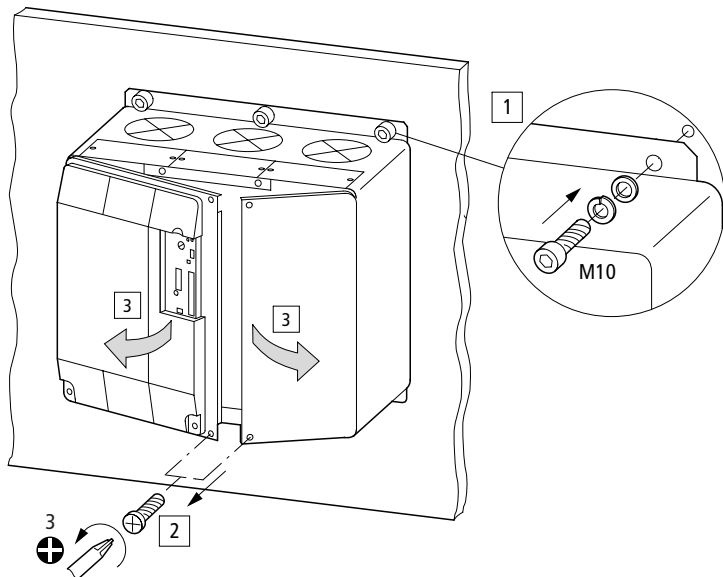

Figure 57: Installation on mounting plate, DM4-340-250K to DM4-340-500K

Mounting instructions are provided with each soft starter.

### Connections



Connect or withdraw the plug-in screw terminals only when the power is off.



The DM4-340 series soft starters have terminals for temperature monitoring. If no temperature sensor is connected, fit a jumper between the thermistor input connectors.

**Caution!**

The devices contain components that are sensitive to electrostatic charges. Before undertaking installation and service work on or near the terminals, discharge yourself by touching a PE mounting screw or another grounded metal surface in the control cabinet.

**Caution!**

Electrical installation and commissioning must be carried out by suitably qualified personnel. You are responsible for implementing suitable grounding and power supply line protection in conformance with local and national regulations. The motor must be protected against overload.

**Caution!**

The soft starter's power section contains semiconductor elements. These do not have isolating properties between mains and load. There is always a leakage current of several milliamps. You should therefore disconnect the starter and motor with an upstream isolating switch before carrying out work on it.

**Connecting the motor cable**

If possible, route all control lines separate from the motor power cable.

The cable cross-sections apply to cables 1L1, 3L2, 5L3, N, 2T1, 4T2 and 6T3.

Connect the PE with a stud. The cable cross-sections required for the soft starter and the tightening torques for the cable terminals are listed in the appendix page 172.

### Screening the motor cables

The motor cables do not need to be screened.

### Connecting the control signal cables

The cross-sections for connecting cables are listed in the technical data (see Appendix, page 172).

The control cable connectors feature a mechanical reverse voltage protection, which prevents an incorrect connection of the internal control inputs.

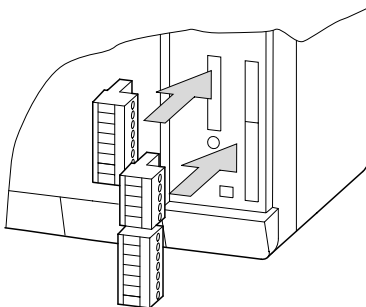

Figure 58: Inserting the plug-in control signal terminals

If the control signal cables (terminal block, relays) are not installed in a single cable run, connect the screening of the two sections to each other with a short grounding cable.

### Screening the control signal cables

**Caution!**

Always screen analog signal cables. To avoid signal distortion, connect the screen at only one cable end.



If the DM4 will be used in environments with extremely high electromagnetic interference, also screen the control signal cables and/or isolate them with coupling relays near the device.

## 5 Operation

### Start-up

The DM4-340 series soft starters are factory-preset to be able to control a power-referenced, standard-conformant 4-pole motor in a typical soft starter application without any modifications.



#### Caution!

Before switching the soft starter on, make sure that the admissible ambient conditions have not been exceeded and that no signs of moisture are visible within the soft starter. Moisture can condense if the soft starter is stored in a cold place. If moisture has entered the device, dry it out completely before use.



#### Caution!

Electrical installation and commissioning must be carried out by suitably qualified personnel. You are responsible for implementing suitable grounding and power supply line protection in conformance with local and national regulations. The motor must be protected against overload.



Do not carry out voltage breakdown tests on any of components of the soft starter. To measure signal voltages, use a suitable measuring device (internal resistance at least 10 k $\Omega$ /V).



Before switching on the soft starter, check that the set controller voltage is the same as your supply voltage.

## Operation

For precise matching of the soft starter to the application, the application selector switch can be used. Select an application that matches your application the most closely. If you are not sure which is the most appropriate application, leave the selector switch on "Standard".

When making changes to the parameters, take the following into account:

- Do not set the ramp time too large.  
If the ramp times are too long, motor acceleration is slow, causing increased motor load for an excessively long time. In extreme cases, the motor may shut down due to overtemperature.
- Do not set the current limit too low.  
If the current supplied to the motor is too low, it cannot generate the torque it needs to accelerate. Acceleration will then be slow, or the motor may not start up at all. If the motor does not accelerate quickly enough, it may be shut down due to overtemperature.

If you want to change parameters yourself, use the values in manual "Soft Starter Design" (AWB8250-1346GB) as a guideline.

---

## Switching on

Before switching on the soft starter, ensure that:

- terminals 7 and 39 are connected if using the internal voltage supply,
- the mains voltage is connected and the device is immediately ready for operation.

Start the drive with a High signal at terminal E1 (Start/Stop).



If you want to adapt the soft starter's parameters to particular applications and the preset options provided by the application selector switch are not suitable, you will need the LCD keypad (DE4-KEY-2) or an interface module.

### Starting the motor

When the start command is applied (High signal at terminal E1 or Run key on the LCD keypad), the motor accelerates at the specified rate. Depending on the load, the actual startup time may deviate from the defined values.



During a start, the soft starter warms up. To prevent overheating, it is essential that you observe the required cooling times. If frequent starts are made in normal operation, a soft starter with a higher rating may have to be used. See Technical Data and manual "Soft Starter Design" (AWB8250-1346GB).

### Operation

On the motor-side, switching is permitted for safety operations (EMERGENCY STOP). You must inhibit the soft starter first, though (see also section "Connection types" on page 31).



#### Caution!

If the motor is switched during normal operation with the soft starter enabled, fault messages may appear and thyristors may be damaged.

The DM4-340 series soft starters are equipped with a heatsink temperature monitor.



#### Warning!

Never open the unit when the mains power supply or the controller supply voltage is switched on, as fatal injury may otherwise result.

**Warning!**

Soft starters are electrical apparatus for use in industrial power installations. During operation, the components of the soft starter can carry dangerous voltages and may also have moving or rotating parts and hot surfaces. These present a risk of serious injury.

**Warning!**

The unauthorized removal of the necessary covers, incorrect installation and operation of the motor or soft starter can lead to failure of the device, serious injury to operating personnel and material damage.

**Warning!**

If the device issues a fault message, the fault must be carefully verified. If a hardware fault is indicated, it is possible that not all phases of the soft starter have been switched off. You must therefore securely disconnect the mains power before carrying out work on the motor (for example by switching the mains switch OFF).

**Caution!**

If the drive is not disconnected from the mains power supply when stationary (at the mains contactor/ mains switch),

- a fault may cause the motor to start unintentionally;
- a voltage may be present at the motor terminals even though the motor is stationary (leakage current through the thyristors).

---

**Stopping**

After the start, the soft starter initiates the operating phase. If you have fitted the LCD keypad, this is shown on the display, together with the output current.

When the t-Dwell time (PNU 15) has expired, the soft starter initializes the optimization phase. By reducing the voltage applied to the motor terminals, the power factor is maintained as near as possible to the optimum value (power factor on the motor's nameplate). This enables the soft starter's output current to be reduced without reducing the drive's speed. This function only applies to drives operating at partial load and is more noticeable with lower rated drives (< 30 kW). If a drive is constantly working at full load, this function can be disabled to avoid instability. Depending on the motor characteristics and load behaviour, the drive may oscillate during p. f. optimization.

---

**Stopping**

When the Stop command is issued (Low signal at terminal E1 or Stop key on LCD keypad DE4-KEY-2), a soft stop is initiated. The drive then decelerates over the specified soft stop time to the stop voltage value. Once this voltage is reached, the soft starter shuts the output down. If the motor is still rotating at this point, it spins down without control.

By default, the soft stop time is 0 s, i. e. the motor deceleration is not controlled by the soft starter.

The Softstop function is particularly useful for pump applications where long soft stop times (> 1 min) are needed to achieve controlled deceleration and to effectively suppress water knock.



## 6 Diagnostics

**Warning!**

Never open the unit when the mains power supply or the controller supply voltage is switched on, as fatal injury could otherwise result.

---

### Troubleshooting

**Motor does not start**

Possible causes:

- Controller enable signal not present
- Start signal not present
- No mains voltage available
- Current limit too low
- Ramp time too long
- Start pedestal too low
- Mode parameter incorrect (In-line, In-delta, etc.)

**Motor stops immediately after start**

Possible causes:

- Shutdown due to fault, such as overload or overtemperature.
- Start signal temporarily interrupted. After the start, a soft stop is initiated, even when a start signal is present again.

**Motor running unevenly**

Possible causes:

- P. f. optimization causes unstable behaviour with some motors.

**Excessive current consumption by motor**

Possible causes:

- Ramp time too long.
- Start pedestal too low.
- Motor overload

**Overcurrent shutdown by soft starter**

Possible causes:

- Motor blocked
- Mismatched soft starter/motor combination
- Monitoring function incorrectly programmed in soft starter
- Motor too small.

**Connected motor is overheating.**

Possible causes:

- Ramp time too long.
- Current limit too low
- Too many successive starts.
- Heavy starting of motor not sufficiently taken into account in motor size selection

---

**Fault messages  
and remedy**

The following messages (except for those signalled by the LEDs) can be viewed only on the LCD keypad or queried through interface modules.

### Fault reset

Current fault messages must be reset before the drive can be restarted. To reset messages, the soft start signal must be disabled. If the motor is controlled via the terminals using default settings, apply a Low signal to terminal E1; if the keypad is used, press the Stop key.

### LED displays

If no LCD keypad or interface is connected to the soft starter, fault messages are displayed by the LEDs on the front panel. The LCD keypad hides the LEDs. The remaining interfaces contain optical conductors, so that the information remains visible.

Red LED	Green LED	Operating status
Off	Off	Device is off.
Off	Flashing	Supply OK, but no start signal.
Off	On	Device working, thyristors activated.
Flashing	Off	Error
On	On	Operation at current limit.
Flashing 3 ×	Flashing 3 ×	Application selector switch operated, changes accepted.
Flashing 3 ×	Off	Application selector switch operated with password set, changes not accepted.

**Diagnostics**

**Monitoring signals**

The following messages are displayed in the LCD keypad.

**Fault messages on Power On**

Message	Fault	Cause	Remedy
OverTemp.	Soft starter's heatsink overheated.	Too many starts	Check configuration and dimensioning; observe pause times.
		Current limit too low	Increase current limit
		Ramp time too long	Reduce ramp time
Thyristor	Fault in thyristor or its control circuit.	Thyristor fault or control circuit failed, e. g. due to mains overvoltages or thermal overload.	Contact manufacturer
		Mode parameter incorrectly set.	Check connection type and adjust Mode parameter accordingly (In-line, In-delta, etc.)
Thy Shorted	Thyristor is always conducting.	Thyristor was damaged, e. g. by mains overvoltages or thermal overload	Contact manufacturer
Thermistor	Motor thermistor has tripped.	Motor is overheated.	Observe pause times, check motor load, check number of motor starts, reduce ramp time, increase current limit.
		If no thermistor is connected, the jumper between terminals T1 and T2 is missing	Fit jumper or set PNU 632 = 0 (Thermistor)

## Fault messages during operation

Displayed message	Fault	Cause	Remedy
PhaseLoss	One or more phases missing on mains side.	Fuse has blown.	Change fuse.
		Faulty wiring.	Check wiring.
OverTemp.	Soft starter's heatsink overheated.	Too many starts.	Check configuration and dimensioning; observe pause times.
		Current limit too low.	Increase current limit.
		Ramp time too long.	Reduce ramp time.
Thyristor	Fault in thyristor or its control circuit.	Thyristor fault or control circuit failed, e. g. due to mains overvoltages or thermal overload.	Contact manufacturer.
	Motor phase missing or thyristor always conducting.	Open circuit in motor cable.	Check wiring.
Firing	Thyristor has not fired.	Fault in thyristor.	Contact manufacturer.
Thy Shorted	Thyristor is always conducting.	Thyristor was damaged, e. g. by mains overvoltages or thermal overload.	Contact manufacturer.
UnderCurrent	Not enough current flowing after top of ramp.	Undercurrent and undercurrent time parameters are incorrectly programmed.	Check plausibility of parameters.
		Motor has no load, e. g. after belt breakage.	Check mechanical components.
Current limit	Drive at set current limit for too long at start.	Current limit too low, drive cannot accelerate.	Increase current limit.
		Ramp time too long, drive remains in high slippage range for too long and cannot accelerate.	Reduce ramp time.

## Diagnostics

Displayed message	Fault	Cause	Remedy
Overload reaction	Motor protection function has responded after startup.	Motor is overloaded.	Check load; check mechanical components.
		Motor is blocked.	Check mechanical components.
		Overload curve incorrectly parameterized.	Check parameters in soft starter.
OverCurrent	Max. overcurrent exceeded.	Motor is too large for soft starter.	Check dimensioning.
		Short-circuit on motor side.	Check motor and motor cable.
		Incorrect parameter settings.	Check parameter settings.

## 7 Menu Structure/ Operating Software

To use the menu structure, LCD keypad DE4-KEY-2 or the DE4-CFG-200 operating software and interface module DE4-COM-2X are required. They are not part of the standard soft starter package content.

---

### Menu structure

The operating menu contains several levels. The first level is the operating level. Here, start/stop commands can be issued and the present current viewed. The menu level is split into the main menus and submenus. Both of these can contain parameters and a variety of functions. The parameters themselves can contain variable values or values from a predefined list. For a detailed description of the individual parameters, see chapter "Defining Parameters" from page 71.

To learn about how to use the keypad and navigate through the menus, see manual "DE4-KEY-2 LCD Keypad" (AWB8250-1344GB).

The table below shows the menu structure with the menus and their parameters.

Main menu	Submenu	Parameter name on display	Brief description of parameter	Page
Basic	–	Drive	Drive Type	77
		Startcommand	Start command selection	77
		Application		77
		U-Start [U-Start 2]	Start pedestal	92
		t-Start [t-Start 2]	Start time	92
		t-Stop [t-Stop 2]	Stop time	92
		Imax-Start [Imax-Start 2]	Current limit reaction	77
		Language	Language selection	90
		Parameterset		78
Config	Control	Startcommand	Start command selection	77
		Mode	Mode	81
		Password	Set/reset password	81
		Parameterset		84
		PAR->KEY	Transfer parameters to keypad	86
		KEY->PAR	Transfer parameters from keypad	86
		PAR1/PAR2	Select parameter sets	86
	Misc	Language	Language selection	78
		Address	Device address	90
		Baud rate	Baud rate	90
		Bus error	Communication behaviour	91
		$I_e$	Nominal device current	90
		Init.Display	Initial display parameter	91

Main menu	Submenu	Parameter name on display	Brief description of parameter	Page
Functions	StartData	U-Start [U-Start 2]	Start pedestal	92
		t-Start [t-Start 2]	Start time	92
		U-Stop [U-Stop 2]	Stop pedestal	92
		t-Stop [t-Stop 2]	Stop time	92
		U-Stopramp [U-Stopramp2]	Stop ramp control	92
		Tmp t-Stop=0	Auto jog	92
		AutoU-Start [AutoU-Start2]	Auto start pedestal	92
		AutoEndStart [AutoEndStrt2]	Auto end start	92
		AutoStopProf [AutoStopPrf2]	Auto stop	107
		AutoEndStop [AutoEndStop2]	Auto end stop	92
		Torque [Torque 2]	(from software version PNU 99 = 53.12) high torque at U-Start > 50 %	93
		SmoothStop	(from software version PNU 99 = 53.12) Activate damping on soft stop	93
		SmoothRate	(from software version PNU 99 = 53.12) degree of damping on soft stop	93

Main menu	Submenu	Parameter name on display	Brief description of parameter	Page	
Functions	Kickstart	U-Kick [U-Kick 2]	Kickstart voltage	96	
		t-Kick [t-Kick 2]	Kickstart time	96	
		Kickstart [Kickstart 2]	Kickstart	96	
	Current		I <sub>max</sub> -Start [I <sub>max</sub> -Start 2]	Current limit reaction	77
			t-I <sub>max</sub> [t-I <sub>max</sub> 2]	Current limit time	97
			I <sub>min</sub> [I <sub>min</sub> 2]	Undercurrent	97
			t-I <sub>min</sub> [t-I <sub>min</sub> 2]	Undercurrent time	97
			UnderCurrent [Undercurr.2]	Undercurrent reaction	97
			Current limit [CurrentLim.2]	Current limit reaction	97
			cos-phi		t-Dwell [t-Dwell 2]
	Rate	Rate of optimization			100
	Protection [Protection 2]	Protection			100
	Digital-In		E1-Pointer	Pointer to a PNU for E1	103
			E1-Logic	Input logic E1	103
			E2-Pointer	Pointer to a PNU for E2	103
			E2-Logic	Input logic E2	103

Main menu	Submenu	Parameter name on display	Brief description of parameter	Page	
Functions	Analog-In	Ref1	Ref 1	104	
		Ref1-Pointer	Pointer to PNU for Ref 1	104	
		Ref1 Level	Ref 1 level	104	
		Ref1 Flag	Ref 1 level bit	104	
		Ref2	Ref 2	105	
		Ref2-Pointer	Pointer to PNU for Ref 2	105	
		Ref2 Level	Ref 2 level	105	
		Ref2 Flag	Ref 2 level bit	105	
		Command 1	Enable	Enable	105
			Kickstart [Kickstart 2]	Kickstart	96
			Current limit [CurrentLim.2]	Current limit reaction	97
			Overload [Overload 2]	Overload reaction	128
			OverCurrent [OverCurrent 2]	OverCurrent	128
			UnderCurrent [Undercurr.2]	Undercurrent reaction	97
	Thermistor [Thermistor 2]		Thermistor	126	
	Command 2		U-Stopramp [U-Stopramp2]	Stop ramp control	92
			Invert Ref0 [Invert Ref0 2]	Invert reference	108
			OptionStart	Keypad start/stop	106
		TerminiStart	Terminals start/stop	106	
		Run relay	Run relay	106	
		PAR1/PAR2	Parameter set selection	86	
		Tmp t-Stop=0	Overwrite stop ramp	92	

Main menu	Submenu	Parameter name on display	Brief description of parameter	Page
Functions	Command 2	t-Start = 0 [t-Start = 0 2]	(from software version PNU 99 = 53.12) Overwrite start time with zero (temporary).	106
		Command 3	Pf1-Logic	not used
	Pf2-Logic		not used	107
	Set I <sub>max</sub>		Set current limit.	107
	ExtFault		External fault.	107
	AutoEndStop [AutoEndStop2]		Auto end stop	92
	AutoStopProf [AutoStopPrf2]		Auto stop	107
	AutoEndStart [AutoEndStrt2]		Auto end start	92
	AutoU-Start [AutoU-Start2]		Auto start pedestal	92
	AutoBypass [AutoBypass 2]		Detect connected bypass and automatically switch parameter protection to the value "Start+Bypass".	107
	Open-loop phase control		KI	Voltage regulator, I-part
		U <sub>max</sub>	U <sub>max</sub>	108
		Invert Ref0 [InvertRef0 2]	Invert reference	108
		Ref0-Pointer	Pointer to reference	108
		FeedBackPntr	Feedback pointer	108
		KP (Mul)	Voltage regulator P-part (gain)	108
		KP (Div)	Voltage regulator, P-part (divide)	108
		UserParametr	User parameter	108

Main menu	Submenu	Parameter name on display	Brief description of parameter	Page	
Indications	Device Data	Address	Device address	90	
		Drive Type	Soft starter type	110	
		SoftwareType	SoftwareType	110	
		Software Ver	Software version	110	
		Software Dat	Software date	110	
		$I_e$	Rated device current	90	
	Status 1	Stopped	Stopped	110	
		Ramp	Ramp function active	110	
		Imax-Limit	Current limit	110	
		Top of Ramp	Top of Ramp	110	
		t-Dwell off	Dwell	111	
		Umax reached	Max. output voltage reached	111	
		Optimising	Optimising	111	
		Stop-Ramp	Stop ramp function active	111	
		Status 2	Alarm	Alarm	111
			Overload>0	Overload reaction	111
	Stalling		Stalling	111	
	Full Load		Full load operation	111	
	Noise		Noise	111	
	Ref 1 flag		Ref 1 level bit	104	
	Ref 2 flag		Ref 2 level bit	105	
	Status 3	StartPause	(from software version PNU 99 = 53.12) waiting time status before the next start.	112	
		Relay K1	Relay K1	112	
		Relay K2	Relay K2	112	
		Relay K3	Relay K3	112	
		Relay K4	Relay K4	112	

Main menu	Submenu	Parameter name on display	Brief description of parameter	Page	
Indications	Status 3	Digi-In. E1	Digital input E1	112	
		Digi-In. E2	Digital input E2	112	
	Status 4	50/60 Hz	50/60 Hz	112	
		Rotation	Direction of rotation	112	
		OverCurr.LIM	Overcurrent limit reached	112	
		UnderCurr.LIM	UnderCurrent	112	
		Thermis.LIM	Thermistor	126	
		Display	cos-phi ref	p. f. Ref	113
	cos-phi		p. f.	113	
	Delay angle		Delay angle	113	
	Max.Delay		Max. optimization, max. delay angle at optimization	113	
	LoadCurrent		Load current (in amperes)	113	
	PeakCurrent		Peak load current (in amperes)	113	
	Overload-Sum		Overload integrator	113	
	T-Heatsink		Heatsink temperature	113	
	Ref 1		Ref 1	104	
	Ref 2		Ref 2	105	
	ThermistorVal		Thermistor actual value	113	
	Load		Device load (in multiples of $I_e$ )	114	
	PeakLoad		Max. unit load (in multiples of $I_e$ )	114	
	Analog-Out		AnOut1Pntr	Pointer to PNU for Analog Out 1	114
			AnOut2Pntr	Pointer to PNU for Analog Out 2	114

Main menu	Submenu	Parameter name on display	Brief description of parameter	Page
Monitoring	Relay K1	K1-Pointer	Pointer to PNU for K1	118
		K1-Logic	Output polarity K1	118
		K1-delaytime	Contact delay	118
	Relay K2	K2-Pointer	Pointer to PNU for K2	124
		K2-Logic	Output polarity K2	124
	Relay K3	K3-Pointer	Pointer to PNU for K3	124
		K3-Logic	Output polarity K3	124
	Relay K4	K4-Pointer	Pointer to PNU for K4	114
		K4-Logic	Output polarity K4	124
	Heatsink	T-Heatsink	Heatsink temperature	113
		Temp.Limit	Temperature limit	125
		StartMonitor	(from software version PNU 99 = 53.12) Activate waiting time function before the next start.	125
		t-Pause	(from software version PNU 99 = 53.12) Waiting time before next start	125
	Thermistor	ThermistorVal	Thermistor actual value	113
		Thermis.LIM	Thermistor status	126
		Thermistor [Thermistor 2]	Thermistor reaction	126
	Motorprotect	OverCurr.max [OverCurr-Max2]	Overcurrent limit	128
		t-Overcurr. [t-Overcurr2]	Overcurrent time	128
		OverCurrent [OverCurrent 2]	Overcurrent	128
		Overload max [OverloadMax2]	Overload limit	128

Main menu	Submenu	Parameter name on display	Brief description of parameter	Page
Monitoring	Motorprotect	t-Overload [t-Overload 2]	Overload delay	128
		Overload-Sum	Overload integrator	113
		Overload [Overload 2]	Overload reaction	128
Error	–	Trip-Sens.	Trip sensitivity	131
		TripHistory1	Last trip	131
		TripHistory2	Second from last fault	131
		TripHistory3	Third from last fault	131
		TripHistory4	Fourth from last fault	131
		TripHistory5	Fifth from last fault	131

### Special features of the LCD keypad

The LCD keypad uses the status indication of the DE4KEY2 LCD keypad as follows:

Status message	Use
RDY	The device is ready for operation. When a soft start command is issued, the soft start is initiated. The display is linked to the Enable message.
IMP	The power section is disabled and the flow of current interrupted. The display is linked to the Run Relay message. Caution: Due to leakage current, the output side is always live!
Imax	Is lit during the start when the drive has reached the set current limit. When ramping is completed, this message goes out, even if the current limit is exceeded. This is because the current limiting function applies only to the soft start, not to continuous operation. The display is linked to the Imax-Limit message.
Mmax	Top of ramp reached; voltage is applied to the motor. The motor is now able to deliver its maximum torque. The display is linked to the Top of Ramp message.
Fault	A fault message was issued.

## Appendix

### Standards

Standard type	Standard	Title	Limit values
Mounting	IP20 to EN 60947-1 (EN 60529)		
Interference immunity	IEC 1000-4-2	Electrostatic discharge	6 kV air discharge, 8 kV contact discharge
	IEC 1000-4-3	Electromagnetic fields Frequency range 80 to 1000 MHz	10 V/m
	IEC 1000-4-6	High frequency field Frequency range 0.15 to 80 MHz, 80 % amplitude-modulated	140 dB $\mu$ V
	IEC 1000-4-4	Fast transients, burst to power terminals	2 kV/5 kHz
		Burst on bus and control cables	2 kV/5 kHz
	IEC 1000-4-5	Surge voltage test, mains power cable	2 kV phase ground 1 kV phase ground
Emission	EN 60947-4-2	Radio interference, housing and mains	Class A for use in industrial environments
			Class B with bypass contactor for use in residential environments
Insulation resistance	Insulation resistance test to EN 60947-1, Annex K		
Admissible pollution	Degree of pollution 2 to EN 60947-1		
Permissible humidity	Relative humidity 85 %, non-condensing		

Technical data

	DM4-340-...			
	...-7K5	...-11K	...-15K	...-22K
<b>Main contacts</b>				
Rated operational voltage [V]	230 to 460 V AC			
Rated insulation voltage $U_i$ [V]	460 V AC			
Mains frequency [Hz]	50/60 Hz			
Power supply, control section [V]	110/230 V AC			
Rated operating current $I_e$ AC-53 [A]	16	23	30	44
Assigned motor rating (standard connection)				
230 V [kW]	4	5.5	7.5	11
400 V [kW]	7.5	11	15	22
460 V [HP]	10	15	20	30
Phase current at in-delta connection [A]	27	39	51	76
Assigned motor rating (in-delta connection)				
230 V [kW]	7.5	11	15	22
400 V [kW]	11	15	22	37
460 V [HP]	20	25	30	50

	...-30K	...-37K	...-45K	...-55K	...-75K	...-90K
Rated operational voltage [V]	230 to 460 V AC					
Rated insulation voltage $U_i$ [V]	460 V AC					
Mains frequency [Hz]	50/60 Hz					
Power supply, control section [V]	110/230 V AC					
Rated operating current $I_e$ AC-53 [A]	59	72	85	105	146	174
Assigned motor rating (standard connection)						
230 V [kW]	15	18.5	22	30	37	45
400 V [kW]	30	37	45	55	75	90
460 V [HP]	40	50	60	75	100	125
Phase current at in-delta connection [A]	102	124	147	181	252	301
Assigned motor rating (in-delta connection)						
230 V [kW]	30	37	45	55	75	90
400 V [kW]	55	55	75	90	132	160
460 V [HP]	75	100	100	150	200	250

	DM4-340-...			
	...-7K5	...-11K	...-15K	...-22K
<b>General</b>				
Standards and regulations	IEC/EN 60947-4-2			
Climatic proofing	Damp heat, cyclical, to DIN IEC 60068 Part 2-10; Damp heat, constant, to DIN IEC 60068 Part 23			
Ambient temperature	0 to 40 °C (to 50 °C with a reduction of $I_e$ of 2 % per °C)			
Storage temperature	-25 to +55 °C			
Installation height	0 to 1000 m, up to 2000 m with a current drop of 1 % per 100 m			
Mounting position	Vertical			
Degree of protection	IP20			
Contact protection	Back-of-hand and finger-proof			
Degree of pollution	2			
Power dissipation at rated operational current $I_e$ [W]	50	63	91	120
Dimensions (W × H × D) [mm]	222 × 290 × 195			
Weight [kg]	6.7			

	DM4-340-...					
	...-30K	...-37K	...-45K	...-55K	...-75K	...-90K
<b>General</b>						
Standards and regulations	IEC/EN 60947-4-2					
Climatic proofing	Damp heat, cyclical, to DIN IEC 60068 Part 2-10; Damp heat, constant, to DIN IEC 60068 Part 2-3					
Ambient temperature	0 to 40 °C (to 50 °C with a reduction of $I_e$ of 2 % per °C)					
Storage temperature	-25 to +55 °C					
Installation height	0 to 1000 m, up to 2000 m with a current drop of 1 % per 100 m					
Mounting position	Vertical					
Degree of protection	IP20					
Contact protection	Back-of-hand and finger-proof					
Degree of pollution	2					
Power dissipation at rated operational current $I_e$ [W]	152	190	227	276	380	452
Dimensions (W × H × D) [mm]	222 × 290 × 195		222 × 420 × 195			338 × 520 × 248
Weight [kg]	6.7		15			15.7

	DM4-340-...
	...-7K5   ...-11K   ...-15K   ...-22K
<b>Cable cross-sections</b>	
Power cables	
Solid [mm <sup>2</sup> ]	1 × (1.5 to 16); 2 × (1 to 4)
Flexible with ferrule/cable lug [mm <sup>2</sup> ]	1 × (1 to 16); 2 × (1 to 4)
Stranded/with cable lug [mm <sup>2</sup> ]	1 × (2.5 to 25); 2 × (2.5 to 4)
Solid or stranded	
Min. AWG	12
Max. AWG	4
Band [mm]	–
Tightening torque [Nm]	2
Screwdriver [mm]	0.8 × 4
Control cables	
Solid [mm <sup>2</sup> ]	1 or 2 × (0.75 to 2.5)
Flexible with ferrule [mm <sup>2</sup> ]	1 or 2 × (0.75 to 2.5)
Stranded [mm <sup>2</sup> ]	1 or 2 × (0.75 to 2.5)
Solid or stranded	
Min. AWG	22
Max. AWG	12
Band [mm]	–
Tightening torque [Nm]	0.5
Screwdriver [mm]	0.6 × 3.5

	...-30K   ...-37K   ...-45K   ...-55K   ...-75K   ...-90K
	M8 stud for cable lug
1 × (4 to 35); 2 × (4 to 10)	–
1 × (6 to 35); 2 × (6 to 10)	–/35 to 95
1 × (10 to 50); 2 × 10	–/50 to 120
10	1-0
1	250 MCM
–	6 × 16 × 0.8
3	12
1.2 × 6.5	–
1 or 2 × (0.75 to 2.5)	
1 or 2 × (0.75 to 2.5)	
1 or 2 × (0.75 to 2.5)	
22	
12	
–	
0.5	
0.6 × 3.5	

	DM4-340-...
	...-7K5    ...-11K    ...-15K    ...-22K
<b>Control circuit</b>	
Current consumption of controller supply	110 V/0.15 A; 230 V/0.07 A
Current consumption of inputs	
Digital inputs	24 V/0.45 mA; 230 V/4.5 mA
Analog inputs	10 V/1 mA
Pick-up voltage	
DC-operated	+12 to +230 V DC
AC-operated	+24 to 230 V AC
Drop-out voltage	
DC-operated	0 to +3 V DC
AC-operated	0 to 3 V AC
Programmable relay outputs	
Number	4
Voltage range [V]	250 V AC
Current range [A]	3 A, AC-11
Programmable analog outputs	
Number	2
Voltage range [V]	0 to 10 V DC
Current range [A]	4 to 20 mA

	...-30K    ...-37K    ...-45K    ...-55K    ...-75K    ...-90K
Current consumption of controller supply	110 V/0.15 A; 230 V/0.07 A
Current consumption of inputs	
Digital inputs	24 V/0.45 mA; 230 V/4.5 mA
Analog inputs	10 V/1 mA
Pick-up voltage	
DC-operated	+12 to +230 V DC
AC-operated	+24 to 230 V AC
Drop-out voltage	
DC-operated	0 to +3 V DC
AC-operated	0 to 3 V AC
Programmable relay outputs	
Number	4
Voltage range [V]	250 V AC
Current range [A]	3 A, AC-11
Programmable analog outputs	
Number	2
Voltage range [V]	0 to 10 V DC
Current range [A]	4 to 20 mA

	DM4-340-...
	...-7K5   ...-11K   ...-15K   ...-22K
<b>Soft start functions</b>	
Ramp times	
Acceleration [s]	1 to 255
Delay [s]	0 to 255
Starting voltage (= breaking voltage) [V]	10 % to 60 %
Voltage drop at stop [V]	0 % to 100 %
Kickstart	
voltage [V]	60 % to 90 %
Duration	
50 Hz	200 to 800 ms
60 Hz	166 to 664 ms
Current limit [A]	1 to 8 $I_e$

...-30K   ...-37K   ...-45K   ...-55K   ...-75K   ...-90K
1 to 255
0 to 255
10 % to 60 %
0 % to 100 %
60 % to 90 %
200 to 800 ms
166 to 664 ms
1 to 8 $I_e$

	DM4-340-...			
	...-110K	...-132K	...-160K	...-200K
<b>Main contacts</b>				
Rated operational voltage [V]	230 to 460 V AC			
Rated insulation voltage $U_i$ [V]	460 V AC			
Mains frequency [Hz]	50/60 Hz			
Power supply, control section [V]	110/230 V AC			
Rated operational current $I_e$ AC-53 [A]	202	242	300	370
Assigned motor rating (standard connection)				
230 V [kW]	55	75	90	110
400 V [kW]	110	132	160	200
460 V [HP]	150	200	250	300
Phase current at in-delta connection [A]	349	419	519	640
Assigned motor rating (in-delta connection)				
230 V [kW]	110	132	160	200
400 V [kW]	160	200	250	315
460 V [HP]	250	350	400	500

	...-250K		...-315K		...-400K		...-500K	
	Rated operational voltage [V]	230 to 460 V AC						
Rated insulation voltage $U_i$ [V]	460 V AC							
Mains frequency [Hz]	50/60 Hz							
Power supply, control section [V]	110/230 V AC							
Rated operational current $I_e$ AC-53 [A]	500		600		750		900	
Assigned motor rating (standard connection)								
230 V [kW]	132		160		200		250	
400 V [kW]	250		315		400		500	
460 V [HP]	400		500		600		750	
Phase current at in-delta connection [A]	866		1039		1299		1558	
Assigned motor rating (in-delta connection)								
230 V [kW]	250		315		400		500	
400 V [kW]	400		560		750		900	
460 V [HP]	600		750					

	DM4-340-...			
	...-110K	...-132K	...-160K	...-200K
<b>General</b>				
Standards and regulations	IEC/EN 60947-4-2			
Climatic proofing	Damp heat, cyclical, to DIN IEC 60068 Part 2-10; Damp heat, constant, to DIN IEC 60068 Part 2-3			
Ambient temperature	0 to 40 °C (to 50 °C with a reduction of $I_e$ of 2 % per °C)			
Storage temperature	-25 to +55 °C			
Installation height	0 to 1000 m, up to 2000 m with a current drop of 1 % per 100 m			
Mounting position	Vertical			
Degree of protection	IP20			
Contact protection	Back-of-hand and finger-proof			
Degree of pollution	2			
Power dissipation at rated operational current $I_e$ [W]	545	662	795	925
Dimensions (W × H × D) [mm]	338 × 520 × 248			
Weight [kg]	15.7	22	22	22

	DM4-340-...			
	...-250K	...-315K	...-400K	...-500K
<b>General</b>				
Standards and regulations	IEC/EN 60947-4-2			
Climatic proofing	Damp heat, cyclical, to DIN IEC 60068 Part 2-10; Damp heat, constant, to DIN IEC 60068 Part 2-3			
Ambient temperature	0 to 40 °C (to 50 °C with a reduction of $I_e$ of 2 % per °C)			
Storage temperature	-25 to +55 °C			
Installation height	0 to 1000 m, up to 2000 m with a current drop of 1 % per 100 m			
Mounting position	Vertical			
Degree of protection	IP20			
Contact protection	Back-of-hand and finger-proof			
Degree of pollution	2			
Power dissipation at rated operational current $I_e$ [W]	1371	1705	2106	2775
Dimensions (W × H × D) [mm]	640 × 610 × 375			
Weight [kg]	56	65	72	72

	DM4-340-...			
	...-110K	...-132K	...-160K	...-200K
<b>Cable cross-sections</b>				
Power cables	M8 stud for cable lug			
Solid [mm <sup>2</sup> ]	-			
Flexible with cable lug [mm <sup>2</sup> ]	2 × (35 to 95)			
Stranded with cable lug [mm <sup>2</sup> ]	2 × (50 to 120)			
Solid or stranded				
Min. AWG	2 × 1/0			
Max. AWG	2 × 250 MCM			
Band [mm]	6 × 16 × 0.8			
Copper rail [mm]	-			
Tightening torque [Nm]	12			
Control cables				
Solid [mm <sup>2</sup> ]	1 × (0.75 to 2.5)			
Flexible with ferrule [mm <sup>2</sup> ]	1 × (0.75 to 2.5)			
Stranded [mm <sup>2</sup> ]	1 × (0.75 to 2.5)			
Solid or stranded				
Min. AWG	22			
Max. AWG	12			
Band [mm]	-			
Tightening torque [Nm]	0.5			
Screwdriver [mm]	0.6 × 3.5			

	...-250K		...-315K		...-400K		...-500K	
	Power cables	2 × M12 screws for cable lug		2 × M12 screws for busbar connection				
Solid [mm <sup>2</sup> ]	-		-		-		-	
Flexible with cable lug [mm <sup>2</sup> ]	2 × (50 to 240)		-		-		-	
Stranded with cable lug [mm <sup>2</sup> ]	2 × (70 to 240)		-		-		-	
Solid or stranded								
Min. AWG	2 × 2/0		-		-		-	
Max. AWG	2 × 500 MCM		-		-		-	
Band [mm]	2 × (10 × 21 × 1)		-		-		-	
Copper rail [mm]	30 × 10		45 × 20; 60 × 10; 80 × 10					
Tightening torque [Nm]	24							
Control cables								
Solid [mm <sup>2</sup> ]	1 × (0.75 to 2.5)		1 × (0.75 to 2.5)		1 × (0.75 to 2.5)		1 × (0.75 to 2.5)	
Flexible with ferrule [mm <sup>2</sup> ]	1 × (0.75 to 2.5)		1 × (0.75 to 2.5)		1 × (0.75 to 2.5)		1 × (0.75 to 2.5)	
Stranded [mm <sup>2</sup> ]	1 × (0.75 to 2.5)		1 × (0.75 to 2.5)		1 × (0.75 to 2.5)		1 × (0.75 to 2.5)	
Solid or stranded								
Min. AWG	22		22		22		22	
Max. AWG	12		12		12		12	
Band [mm]	-		-		-		-	
Tightening torque [Nm]	0.5		0.5		0.5		0.5	
Screwdriver [mm]	0.6 × 3.5		0.6 × 3.5		0.6 × 3.5		0.6 × 3.5	

	DM4-340-...			
	...-110K	...-132K	...-160K	...-200K
<b>Control circuit</b>				
Current consumption of controller supply	110 V/0.15 A; 230 V/0.07 A			
Current consumption of inputs				
Digital inputs	24 V/0.45 mA; 230 V/4.5 mA			
Analog inputs	10 V/1 mA			
Pick-up voltage				
DC-operated	+12 to +230 V DC			
AC-operated	+24 to 230 V AC			
Drop-out voltage				
DC-operated	0 to +3 V DC			
AC-operated	0 to 3 V AC			
Programmable relay outputs				
Number	4			
Voltage range [V]	250 V AC			
Current range [A]	3 A, AC-11			
Programmable analog outputs				
Number	2			
Voltage range [V]	0 to 10 V DC			
Current range [A]	4 to 20 mA			

	DM4-340-...			
	...-250K	...-315K	...-400K	...-500K
<b>Control circuit</b>				
Current consumption of controller supply	110 V/1.4 A; 230 V/0.8 A			
Current consumption of inputs				
Digital inputs	24 V/0.45 mA; 230 V/4.5 mA			
Analog inputs	10 V/1 mA			
Pick-up voltage				
DC-operated	+12 to +230 V DC			
AC-operated	+24 to 230 V AC			
Drop-out voltage				
DC-operated	0 to +3 V DC			
AC-operated	0 to 3 V AC			
Programmable relay outputs				
Number	4			
Voltage range [V]	250 V AC			
Current range [A]	3 A, AC-11			
Programmable analog outputs				
Number	2			
Voltage range [V]	0 to 10 V DC			
Current range [A]	4 to 20 mA			

	DM4-340-...
	...-110K   ...-132K   ...-160K   ...-200K
<b>Soft start functions</b>	
Ramp times	
Acceleration [s]	1 to 255
Delay [s]	0 to 255
Start pedestal (= stop pedestal) [V]	10 % to 60 %
Voltage drop at stop [V]	0 % to 100 %
Kickstart	
voltage [V]	60 % to 90 %
Duration [s]	
50 Hz	200 to 800 ms
60 Hz	166 to 664 ms
Current limit [A]	1 to 8 $I_e$

	...-250K   ...-315K   ...-400K   ...-500K
1 to 255	
0 to 255	
10 % to 60 %	
0 % to 100 %	
60 % to 90 %	
200 to 800 ms	
166 to 664 ms	
1 to 8 $I_e$	

## Control inputs/outputs

Terminal	Function	Def	Current consumption, load rating
<b>Digital inputs</b>			
E1	Programmable control input	Start/stop	24 V DC, 0.45 mA
E2	Programmable control input	Enable	230 V AC, 4.5 mA
39	0 V reference for E1 and E2	–	
<b>Analog inputs</b>			
8	Setpoint 0 to 10 V DC		10 V DC, 1 mA 5 V AC, 0.4 mA
1	Setpoint 4 to 20 mA		
7	0 V reference for terminal +12, 1, 8, 62 and 63	–	
<b>Analog outputs</b>			
62	Programmable analog output	Output current	0 to 10 V DC, 10 mA
63	Programmable analog output	Delay angle	0 to 10 V DC, 10 mA
7	0 V reference for terminal +12, 1, 8, 62 and 63	–	
+12 V	Internal power for supplying setpoint potentiometers and digital inputs	–	+12 V, 120 mA

Terminal	Function	Def	Current consumption, load rating
<b>Relay outputs</b>			
13	Programmable make contact K1	OK	230 V AC, 3 A, AC-11
14	Supply to K1		
23	Programmable make contact K2	TOR – top of ramp	
24	Supply to K2		
33	Programmable make contact K3	Alarm	
34	Supply to K3 and K4		
35	Programmable make contact K4	Overload operation	
<b>Thermistor input</b>			
T1	Thermistor input to IEC 60034-11	Not active	–
T2			

## Appendix

**Overload withstand capability**

The table below shows the overload rating of the soft starter according to product standard IEC/EN 60947-4-2.

DM4-340-...	Overcurrent X	Overcurrent duration Tx [s]	Duty factor F [%]	Starts per hour S	Off
-------------	---------------	-----------------------------	-------------------	-------------------	-----

**Overload rating without bypass (loading to AC-53a)**

...-7K5 to -55K	3	35	99	10	–
	5	4	99	10	–
...-75K to -90K	3	35	99	10	–
	4	6	99	10	–
...-110K to -132K	3	35	60	10	–
	4	6	60	10	–
...-160K to -500K	3	35	60	3	–
	4	6	60	3	–

**Overload rating with bypass (loading to AC-53b)**

...-7K5 to -55K	3	35	–	–	120
	5	4	–	–	120
...-75K to -90K	3	35	–	–	120
	4	6	–	–	120
...-110K to -132K	3	35	–	–	360
	4	6	–	–	360
...-160K to -500K	3	35	–	–	360
	4	6	–	–	360

X = Level of basic overcurrent in multiples of the device rated current

Tx = Duration of overcurrent in seconds

F = Duty factor within the load cycle in %

S = Number of starts per hour

Off = Minimum (zero current) time between two starts in seconds

**Conversion of overload withstand capability to lower overcurrents**

The specified cycle can be converted for lower overcurrents according to the formula below, but not for higher ones.

$$T_{x_{\text{new}}} = \frac{X^2 \times T_x}{X_{\text{new}}^2}$$

$X_{\text{new}}$  = Required overcurrent  
(must be less than the specified values)

$T_{x_{\text{new}}}$  = New admissible time for the new overcurrent  $X_{\text{new}}$

Example:

for  $X = 3$ ,  $T_x = 35$  s; calculate  $T_x$  for  $X = 2.5$

$$T_{x_{\text{new}}} = \frac{3^2 \times 35 \text{ s}}{2.5^2} = 50 \text{ s}$$



Other overload cycles/operating frequencies on request.

## Parameters/equipment

Abbreviation	Use
PNU	Parameter number
PNU 000 [2000]	Parameter can have different values in parameter set 1 and parameter set 2. The PNU for parameter set 2 is given in square brackets.
PNU 000	Parameter always has the same value in parameter set 1 and parameter set 2, but is shown only in parameter set 1.
(= PNU 000)	Parameter has the inverse state of the specified parameter.
✓	Available
%	Not applicable/not used
ONLINE	Direct transfer of values
SH + PRG	Values accepted when SHIFT + PRG is pressed
SH + PRG/dis	Values accepted when controller disable active and SHIFT + PRG is pressed.
rw	Parameter has read/write access.
ro	Parameter is read-only.
w=exe	Parameter is a command; can only be executed (save = execute).

**Parameter types**

The following parameter types are defined. You will need this information for transferring data through an interface.

Type	Use
Fix32	<p>The parameter value is a 32-bit integer. It is represented as a number with fixed decimal point and four decimal places. To determine the value to be sent to the soft starter, multiply this value with 10000. The integer component of the result is the transferred value, e. g.:</p> <p>Transfer 37.8473933 -&gt; <math>\times 10000 = 378473.933</math> -&gt; INT -&gt; send 378473            Transfer 1 -&gt; <math>\times 10000 = 10000</math> -&gt; INT -&gt; send 10000</p> <p>The digits after the decimal point are omitted. The same encoding is used for transmission from soft starter to programmable controller. The sent integer value must be divided by 10000 to obtain the actual parameter value.</p>
Int16	The parameter value is stored as a 16-bit integer. No conversions are necessary.
Bit16	The data is a 16-bit string. The data is coded bitwise (status bit, control bits).

## Parameter table (PNU)

PNU	Parameter name on display	PNU	Parameter name on display	PNU	Parameter name on display
1	Startcommand	27	PeakCurrent	55	Load
2	KEY->PAR	28	Imin	56	PeakLoad
3	PAR->KEY	[2028]	[Imin 2]	57	K1-Pointer
4	Init.Display	29	t-Imin	59	K2-Pointer
5	Password	[2029]	[t-Imin 2]	61	K3-Pointer
6	Mode	30	Imax-Start	62	Parameterset
7	Protection	[2030]	[Imax-Start 2]	63	K4-Pointer
[2007]	[Protection 2]	31	t-Imax	65	E1-Pointer
9	Address	[2031]	[t-Imax 2]	66	Language
11	U-Start	32	OverCurr.max	67	E2-Pointer
[2011]	[U-Start 2]	[2032]	[OverCurr-Max2]	71	K1-delaytime
12	t-Start	33	t-Overcurr.	72	Trip-Sens.
[2012]	[t-Start 2]	[2033]	[t-Overcurr2]	93	Drive Type
13	U-Kick	34	Overload max	99	Software Ver
[2013]	[U-Kick 2]	[2034]	[OverloadMax2]	105	Ref0-Pointer
14	t-Kick	35	t-Overload	106	FeedBackPntr
[2014]	[t-Kick 2]	[2035]	[t-Overload 2]	107	KP (Mul)
15	t-Dwell	36	Overload-Sum	108	KP (Div)
[2015]	[t-Dwell 2]	37	T-Heatsink	109	KI
16	U-Stop	40	Enable	110	Umax
[2016]	[U-Stop 2]	41	Ref2 Level	111	UserParametr
17	t-Stop	42	ThermistorVal	113	Drive
[2017]	[t-Stop 2]	43	Ref2	115	Application
19	Rate	44	Temp.Limit	116	(From software version PNU 99 = 53.12) t-Pause
20	cos-phi ref	45	Ref2-Pointer		
21	cos-phi	46	Ref1		
22	Delay angle	47	Ref1-Pointer	122	(from software version PNU 99 = 53.12) SmoothRate
23	Max.Delay	48	Ref1 Level		
24	le	49	AnOut1Pntr		
26	LoadCurrent	50	AnOut2Pntr	125	Baud rate

PNU	Parameter name on display	PNU	Parameter name on display	PNU	Parameter name on display
126	Bus error	624	OverCurr.LIM	647	AutoEndStart
135	ComCommandW	625	UnderCurr.LIM	[2647]	[AutoEndStart2]
150	ComStatusW	626	Thermis.LIM	648	AutoU-Start
161	TripHistory1	627	Kickstart	[2648]	[AutoU-Start2]
162	TripHistory2	[2627]	[Kickstart 2]	649	K1-Logic
163	TripHistory3	628	Current limit	650	K2-Logic
164	TripHistory4	[2628]	[CurrentLim.2]	651	K3-Logic
165	TripHistory5	629	Overload	652	K4-Logic
200	SoftwareType	[2629]	[Overload 2]	653	E1-Logic
201	Software Dat	630	OverCurrent	654	E2-Logic
600	Stopped	[2630]	[OverCurrent 2]	655	AutoBypass
601	Ramp	631	UnderCurrent	[2655]	[AutoBypass 2]
602	Imax-Limit	[2631]	[Undercurr.2]	669	(from software version PNU 99 = 53.12) SmoothStop
603	Top of Ramp	632	Thermistor	670	(from software version PNU 99 = 53.12) Torque
604	t-Dwell off	[2632]	[Thermistor 2]	[2670]	
605	Umax reached	633	Not Enable	671	(From software version PNU 99 = 53.12) t-Start = 0
606	Optimising	634	U-Stopramp	[2671]	[t-Start = 0 2]
607	Stop-Ramp	[2634]	[U-Stopramp2]	672	(From software version PNU 99 = 53.12) StartPause
608	Alarm	635	Invert Ref0	673	(From software version PNU 99 = 53.12) StartMonitor
609	Overload>0	[2635]	[InvertRef0 2]		
610	Stalling	636	OptionStart		
611	Full Load	637	TerminlStart		
612	Noise	638	Run relay		
614	Ref1 Flag	639	PAR1/PAR2		
615	Ref2 Flag	640	Tmp t-Stop=0		
616	Relay K1	641	Pf1-Logic		
617	Relay K2	642	Pf2-Logic		
618	Relay K3	643	Set Imax		
619	Relay K4	644	ExtFault		
620	Digi-In. E1	645	AutoEndStop		
621	Digi-In. E2	[2645]	[AutoEndStop2]		
622	50/60 Hz	646	AutoStopProf		
623	Rotation	[2646]	[AutoStopPrf2]		

Parameter table (alphabetic)

Parameter name on display	PNU	Short description of parameter	Permissible values/meaning
TripHistory1	161	Most recent trip	1 to 16
			0 = No fault
			1 = Phase loss
			2 = Overtemperature
			3 = Thyristor
			4 = Firing
			5 = Thyristor
			6 = Thyristor
			7 = Thyristor
			8 = Thyristor
			9 = Thyristor
			10 = thyristor shorted
			11 = Undercurrent
			12 = Current limit
			13 = Overload
			14 = Max. overcurrent
			15 = Thermistor
16 Default factory setting, no fault			
TripHistory2	162	2nd to last trip	1 to 16
TripHistory3	163	3rd to last trip	1 to 16
TripHistory4	164	4th to last trip	1 to 16
TripHistory5	165	5th to last trip	1 to 16
50/60 Hz	622	50/60 Hz	0 = 50 Hz
			1 = 60 Hz

Value selection on display	Data type	Access rights	Transfer	Def	Main menu	Submenu	Page
1 to 15 Trip after PRG Message text:	Fix32	ro	%		Error		131
No Trip							
PhaseLoss							
OverTemp.							
Thyristor							
Firing							
Thyristor							
Thyristor							
Thyristor							
Thyristor							
Thy Shorted							
UnderCurrent							
Current limit							
Overload reaction							
OverCurr.max							
Thermistor							
Message text							
Message text							
Message text							
Message text							
50 Hz							
60 Hz	Fix32	ro	%		Indications	Status 4	112

Parameter name on display	PNU	Short description of parameter	Permissible values/meaning
Address	9	Device address	1 to 99
Alarm	608	Alarm	0 = Normal operation 1 = Soft starter fault
AnOut1Pntr	49	Pointer to PNU for Analog Out 1	0; 20 to 111
AnOut2Pntr	50	Pointer to PNU for Analog Out 2	0; 20 to 111
Application	115		0 = Standard 1 = Breakaway torque 2 = Small pump 3 = Large pump 4 = Light conveyor 5 = Heavy conveyor 6 = Low inertia fan 7 = High inertia fan 8 = Reciprocating compressor 9 = Screw compressor
AutoBypass [AutoBypass 2]	655 [2655]	Detect connected bypass and automatically switch parameter protection to the value "Start+Bypass"	0 = Off 1 = On
AutoEndStart [AutoEndStrt2]	647 [2647]	Auto end start	0 = Off 1 = Automatic end of start ramp when TOR reached prematurely
AutoEndStop [AutoEndStop2]	645 [2645]	Auto end stop	0 = Off 1 = Automatic end of stop ramp

Value selection on display	Data type	Access rights	Transfer	Def	Main menu	Submenu	Page
1 to 99	Fix32	rw	SH + PRG	3	Indications	Device Data	110
					Config	Misc	110
No	Fix32	ro	%		Indications	Status 2	111
Yes							
Text-List	Fix32	rw	SH + PRG	26 = Load current	Indications	Analog-Out	114
Text-List	Fix32	rw	SH + PRG	22 = Delay angle	Indications	Analog-Out	114
Standard	Fix32	w=exe	SH + PRG/dis	0	Basic	Basic	77
High torque							
Small pump							
Pump W.Kick							
LightConvey							
Heavy conveyor							
LowInert.Fan							
HighInertFan							
RecipCompres							
Screw compressor							
Off	Fix32	rw	SH + PRG	1	Functions	Command 3	107
On							
Off	Fix32	rw	SH + PRG	0	Functions	StartData	92
On						Command 3	107
Off	Fix32	rw	SH + PRG	0	Functions	StartData	92
On						Command 3	92

Parameter name on display	PNU	Short description of parameter	Permissible values/meaning
AutoStopProf [AutoStopProf2]	646 [2646]	Auto stop	0 = Off 1 = Load-dependent reduction of soft stop voltage
AutoU-Start [AutoU-Start2]	648 [2648]	Auto start pedestal	0 = Off 1 = Automatic start pedestal adaption
Baud rate	125	Baud rate	0 to 4
Mode	6	Mode	0 = Soft starter in-line 1 = Soft starter in-delta 2 = Closed-loop phase control 3 = Open-loop phase control 4 = Regulator with earthed star point 5 = Controller with earthed star point
Bus error	126	Communication behaviour	0 = Continue 1 = Disable with fault message
ComStatusW	150	ComStatusW Bit 0 = PNU 639 Bit 1 = PNU 600 Bit 2 = PNU 602 Bit 3 = PNU 603 Bit 4 = PNU 603 Bit 6 = PNU 600 Bit 7 = PNU 40 = hardware and software enable Bit 14 = PNU 623 Bit 15 = PNU 608	Bit 0 = 0: PAR1 = 1: PAR2 Bit 1 = 0: Motor running = 1: Motor stopped Bit 2 = 0: Below the current limit = 1: Current limit PNU 30 reached Bit 3 = 0: In ramp or stop = 1: TOR Bit 4 = 0: TOR = 1: in ramp or stop Bit 6 = 0: In operation = 1: Stopped

Value selection on display	Data type	Access rights	Transfer	Def	Main menu	Submenu	Page
Off	Fix32	rw	SH + PRG	0	Functions	StartData	92
On						Command 3	107
Off	Fix32	rw	SH + PRG	0	Functions	StartData	92
On						Command 3	107
0 to 4	Fix32	rw	SH + PRG	0	Config	Misc	90
Standard	Fix32	rw	SH + PRG/dis	0	Config	Control	81
In-delta							
ClosedLoop							
Open-loop phase control							
ClosedLoop +N							
OpenLoop +N							
Continue	Fix32	rw	SH + PRG	1	Config	Misc	91
Shutdown							
	Bit16	ro			Without		135

Parameter name on display	PNU	Short description of parameter	Permissible values/meaning
ComStatusW	150		Bit 7 = 0: enabled = 1: disabled Bit 8 to 11: device status = 0: Initialization = 3: Disabled (PNU 40 = 0) = 6: Enabled (PNU 40 = 1) = 7: Warning present (PNU 609 = 1) = 8: Fault (PNU 608 = 1) = 15: DM4 switched off (for external interface module supply only) Bit 14 = 0: Clockwise rotation = 1: Anticlockwise rotation Bit 15 = 0: Not ready for operation = 1: Ready for operation
ComCommandW	135	ComCommandW Bit 9 = PNU 40 Bit 12 = PNU 639	Bit 3 = 0: Soft start (Run) = 1: Soft stop (Stop) Bit 9 = 0: Enable = 1: Disable Bit 12 = 0: PAR1 = 1: PAR2 Bit 13 = 0: LockBus = 1: UnlockBus
cos-phi	21	p. f. actual value	0 to 146°
cos-phi ref	20	p. f. reference	0 to 146°
Digi-In. E1	620	Digital input E1	0 = Input signal is Low 1 = Input signal is High
Digi-In. E2	621	Digital input E2	0 = Input signal is Low 1 = Input signal is High
Rotation	623	Direction of rotation	0 = Clockwise rotation 1 = Anticlockwise rotation

Value selection on display	Data type	Access rights	Transfer	Def	Main menu	Submenu	Page
	Bit 16	ro			Without		135
	Bit16	rw			Without		135
0 to 146°	Fix32	ro	%		Indications	Display	113
0 to 146°	Fix32	ro	%		Indications	Display	113
Low	Fix32	ro	%		Indications	Status 3	112
High							
Low	Fix32	ro	%		Indications	Status 3	112
High							
L1/L2/L3	Fix32	ro	%		Indications	Status 4	112
L1/L3/L2							

Parameter name on display	PNU	Short description of parameter	Permissible values/meaning
Torque	670 [2670]	(from software version PNU 99 = 53.12) high torque at U-Start > 50 %	0 = normal 1 = high
Drive Type	93	Soft starter type	10
Drive	113	Drive Type	
E1-Logic	653	Input logic E1	0 = Low for active 1 = High for active
E1-Pointer	65	Pointer to a PNU for E1	0; 627 to 673; 2627 to 2671
E2-Logic	654	Input logic E2	0 = Low for active 1 = High for active
E2-Pointer	67	Pointer to a PNU for E2	0; 627 to 673; 2627 to 2671
ExtFault	644	External fault	0= No fault 1 = external fault
Enable	40	Enable	0 = Disable 1 = Enable
Stopped	600	Stopped	0 = Motor running 1 = Motor stopped
SmoothRate	122	(from software version PNU 99 = 53.12) Degree of damping on soft stop	1 to 25
SmoothStop	669	(from software version PNU 99 = 53.12) activate damping on soft stop with activated U-Stopramp	0 = no 1 = On
le	24	Rated device current	5 to 2000 A

Value selection on display	Data type	Access rights	Transfer	Def	Main menu	Submenu	Page
Normal	Fix32	rw	SH + PRG	0	Functions	StartData	93
High							
10	Fix32	ro	%		Indications	Device Data	110
Text	String	ro	%	Device-dependent	Basic		77
Low = active	Fix32	rw	SH + PRG	1	Functions	Digital-In	103
High = active							
Text-List	Fix32	rw	SH + PRG	637	Functions	Digital-In	103
Low = active	Fix32	rw	SH + PRG	0	Functions	Digital-In	103
High = active							
Text-List	Fix32	rw	SH + PRG	633	Functions	Digital-In	103
No	Fix32	rw	SH + PRG	0	Functions	Command 3	107
Yes							
Disabled	Fix32	rw	Online	1	Functions	Command 1	105, 31
Enabled							
Motor Running	Fix32	ro	%		Indications	Status 1	110
Motor stop							
1 to 25	Fix32	rw	SH + PRG	5	Functions	StartData	93
No	Fix32	rw	SH + PRG	0	Functions	StartData	93
On							
5 to 2000 A Adjustments only by Moeller service	Int16	rw	SH + PRG/dis	Device-dependent	Indications	Device Data	110
					Config	Misc	90

Parameter name on display	PNU	Short description of parameter	Permissible values/meaning
I <sub>max</sub> -Limit	602	Current limit	0 = Current limit from PNU 30 (= I <sub>max</sub> -Start) reached 1 = Output current below value from PNU 30
I <sub>max</sub> -Start [I <sub>max</sub> -Start 2]	30 [2030]	Current limit reaction	0.5 to 8.0 I <sub>e</sub>
I <sub>min</sub> [I <sub>min</sub> 2]	28 [2028]	Undercurrent	0.00 to 1.00 I <sub>e</sub>
Init.Display	4	Initial display parameter	0; 20 to 111
Invert Ref0 [InvertRef0 2]	635 [2635]	Invert reference	0 = Do not invert 1 = Invert reference
FeedBackPntr	106	Feedback pointer	0; 20 to 111
K1-Logic	649	Output polarity K1	0 = Low signal triggers switching 1 = High signal triggers switching
K1-Pointer	57	Pointer to PNU for K1	0; 600 to 673; 2627 to 2671
K1-delaytime	71	Contact delay	20 to 800 ms
K2-Logic	650	Output polarity K2	0 = Low signal triggers switching 1 = High signal triggers switching
K2-Pointer	59	Pointer to PNU for K2	0; 600 to 673; 2627 to 2671
K3-Logic	651	Output polarity K3	0 = Low signal triggers switching 1 = High signal triggers switching
K3-Pointer	61	Pointer to PNU for K3	0; 600 to 673; 2627 to 2671

Value selection on display	Data type	Access rights	Transfer	Def	Main menu	Submenu	Page
reached	Fix32	ro	%		Indications	Status 1	110
not reached							
0.5 to 8.0 I <sub>e</sub>	Fix32	rw	Online	3.5 I <sub>e</sub>	Basic		77
					Functions	Current	97
0.00 to 1.00 I <sub>e</sub>	Fix32	rw	SH + PRG	0.09 I <sub>e</sub>	Functions	Current	97
Text-List	Fix32	rw	SH + PRG	26	Config	Misc	91
MaxIn=MaxOut	Fix32	rw	SH + PRG	1	Functions	Open-loop phase control	108
MaxIn=MinOut						Command 2	108
Text-List	Fix32	rw	SH + PRG	26	Functions	Open-loop phase control	108
Low = On	Fix32	rw	SH + PRG	1	Monitoring	Relay K1	118
High = On							
Text-List	Fix32	rw	SH + PRG	638	Monitoring	Relay K1	118
20 to 800 ms	Fix32	rw	Online	160 ms	Monitoring	Relay K1	118
Low = On	Fix32	rw	SH + PRG	1	Monitoring	Relay K2	124
High = On							
Text-List	Fix32	rw	SH + PRG	603	Monitoring	Relay K2	124
Low = On	Fix32	rw	SH + PRG	1	Monitoring	Relay K3	124
High = On							
Text-List	Fix32	rw	SH + PRG	608	Monitoring	Relay K3	124

Parameter name on display	PNU	Short description of parameter	Permissible values/meaning
K4-Logic	652	Output polarity K4	0 = Low signal triggers switching 1 = High signal triggers switching
K4-Pointer	63	Pointer to PNU for K4	0; 600 to 673; 2627 to 2671
KEY->PAR	2	Transfer parameters from keypad	20 = Execute
KI	109	Voltage regulator, I-part	0 to 50
Kickstart [Kickstart 2]	627 [2627]	Kickstart	0 = Off 1 = Activate kickstart
TerminlStart	637	Terminals start/stop	0 = No signal 1 = Start signal
KP (Div)	108	Voltage regulator, P-part (divide)	1 to 255
KP (Mul)	107	Voltage regulator P-part (gain)	1 to 255
Load	55	Device load (in multiples of $I_e$ )	0.0 to 8.0 $I_e$
LoadCurrent	26	Load current (in amperes)	0 to 2000 A
Max.Delay	23	Max. optimization, max. delay angle at optimization	17 to 146°
Optimising	606	Optimising	0 = p. f. not active 1 = p. f. active
OptionStart	636	Keypad start/stop	0 = No signal/Option not fitted 1 = Start signal
PAR->KEY	3	Transfer parameters to keypad	11 = Execute
PAR1/PAR2	639	Parameter set selection	0 = PAR 1 1 = PAR 2

Value selection on display	Data type	Access rights	Transfer	Def	Main menu	Submenu	Page
Low = On	Fix32	rw	SH + PRG	1	Monitoring	Relay K4	124
High = On							
Text-List	Fix32	rw	SH + PRG	609	Monitoring	Relay K4	124
Execute	%	w=exe	SH + PRG/dis		Config	Control	86
0 to 50	Fix32	rw	Online	10	Functions	Open-loop phase control	108
Off	Fix32	rw	SH + PRG	0	Functions	Kickstart	96
On							
Off	Fix32	ro	%		Functions	Command 2	106
On							
1 to 255	Fix32	rw	Online	7	Functions	Open-loop phase control	108
1 to 255	Fix32	rw	Online	37	Functions	Open-loop phase control	108
0.0 to 8.0 $I_e$	Fix32	ro	%		Indications	Display	114
0 to 2000 A	Fix32	ro	%		Indications	Display	113
17 to 146°	Fix32	ro	%		Indications	Display	113
No	Fix32	ro	%		Indications	Status 1	111
active							
Off	Fix32	rw	SH + PRG	0	Functions	Command 2	106
On							
Execute	%	w=exe	SH + PRG/dis	11	Config	Control	86
PAR 1	Fix32	rw	SH + PRG	0	Functions	Command 2	86
PAR 2							
					Config	Control	86

Parameter name on display	PNU	Short description of parameter	Permissible values/meaning
Parameterset	62		1 = Save parameter set
			2 = Load defaults
			3 = Load power-on
Password	5	Set/reset password	1 to 255
PeakCurrent	27	Peak load current (in amperes)	0 to 2000 A
Pf1-Logic	641	not used	0 = Low = On
			1 = High = On
Pf2-Logic	642	not used	0 = Low = On
			1 = High = On
Ramp	601	Ramp function active	0 = Soft starter not in Ramp
			1 = Soft starter in Ramp
Rate	19	Rate of optimization	4 to 30
Noise	612	Noise	0 = Soft starter working correctly
			1 = excessive external interference voltage
Ref0-Pointer	105	Pointer to reference	0; 20 to 111
Ref1	46	Ref 1	0.0 to 9.9 V
Ref1 Flag	614	Ref 1 level bit	0 = Value at Ref 1 below signalling threshold in PNU 48
			1 = Value at Ref 1 above the signalling threshold in PNU 48

Value selection on display	Data type	Access rights	Transfer	Def	Main menu	Submenu	Page
Save parameters	Fix32	w=exe	SH + PRG/dis		Basic		78
Default					Config	Control	78
Load power-on parameters							
1 to 1255 Display: 255 = No password ≠ 255 = Password set	Fix32	rw	SH + PRG/dis	0	Config	Control	81
0 to 2000 A	Fix32	ro	%		Indications	Display	113
Low = On	Fix32	rw	SH + PRG	1	Functions	Command 3	107
High = On							
Low = On	Fix32	rw	SH + PRG	1	Functions	Command 3	107
High = On							
no ramp	Fix32	ro	%		Indications	Status 1	110
Ramp active							
4 to 30	Fix32	rw	Online	5	Functions	cos-phi	100
No	Fix32	ro	%		Indications	Status 2	111
Too high							
Text-List	Fix32	rw	SH + PRG	46	Functions	Open-loop phase control	108
0.0 to 9.9 V	Fix32	ro	%		Indications	Display	104
					Functions	Analog-In	104
< Ref1 Level	Fix32	ro	%		Indications	Status 2	104
> Ref1 Level					Functions	Analog-In	104

Parameter name on display	PNU	Short description of parameter	Permissible values/meaning
Ref1 Level	48	Ref 1 level	0.1 to 9.9 V
Ref1-Pointer	47	Pointer to PNU for Ref 1	0 = not used 11 to 111, 2011 to 2035
Ref2	43	Ref 2	0.1 to 20.4 mA
Ref2 Flag	615	Ref 2 level bit	0 = Value at Ref 2 below signalling threshold in PNU 41 1 = Value at Ref 2 above the signalling threshold in PNU 41
Ref2 Level	41	Ref 2 level	0.1 to 20.2 mA
Ref2-Pointer	45	Pointer to PNU for Ref 2	0 = not used 11 to 111, 2011 to 2035
Relay K1	616	Relay K1	0 = Relay not energized 1 = Relay energized
Relay K2	617	Relay K2	0 = Relay not energized 1 = Relay energized
Relay K3	618	Relay K3	0 = Relay not energized 1 = Relay energized
Relay K4	619	Relay K4	0 = Relay not energized 1 = Relay energized
Run relay	638	Run relay	0 = Off 1 = Set Run Relay
Protection [Protection 2]	7 [2007]	Protection	0 = Phase failure 64 = activate protection functions 128 = protection functions only at start, then bypass 192 = protection functions and optimization

Value selection on display	Data type	Access rights	Transfer	Def	Main menu	Submenu	Page
0.1 to 9.9 V	Fix32	rw	Online	4.9 V	Functions	Analog-In	104
Text-List	Fix32	rw	SH + PRG	0	Functions	Analog-In	104
0.1 to 20.4 mA	Fix32	ro	%		Indications	Display	105
< Ref2 Level	Fix32	ro	%		Indications	Status 2	105
> Ref2 Level					Functions	Analog-In	105
0.1 to 20.2 mA	Fix32	rw	Online	10.2 mA	Functions	Analog-In	105
Text-List	Fix32	rw	SH + PRG	0	Functions	Analog-In	105
Off	Fix32	ro	%		Indications	Status 3	112
On							
Off	Fix32	ro	%		Indications	Status 3	112
On							
Off	Fix32	ro	%		Indications	Status 3	112
On							
Off	Fix32	ro	%		Functions	Command 2	106
On							
PhaseLoss	Fix32	rw	SH + PRG	128	Functions	cos-phi	100
Protection							
Start+Bypass							
Protect+Opti							

Parameter name on display	PNU	Short description of parameter	Permissible values/meaning
Set lmax	643	Set current limit	0 = Off 1 = Simulate operation at current limit
Software Dat	201	Software date	01/12/14.A
SoftwareType	200	SoftwareType	53BDM434051000
Software Ver	99	Software version	53.18
Not Enable	633	Inverted Enable signal	0 = Enable 1 = Disable
PeakLoad	56	Max. unit load (in multiples of $I_e$ )	0.0 to 8.0 $I_e$
Language	66	Language selection	34 = Spanish 39 = Italian 44 = English 49 = German
Stalling	610	Stalling	0 = Motor working correctly 1 = Motor wants to stall; automatically corrected by soft starter.
Startcommand	1	Start command selection	0 = Start/Stop terminals, app. switch active, key/options read-only 1 = Start/Stop terminals, app. switch active, key/options read-only for App. switch influences parameters, read/write for the rest. 2 = Terminal Start/Stop, app. switch not active, use saved parameters. 3 = Keypad/options Start/Stop, app. switch not active, use saved parameters.

Value selection on display	Data type	Access rights	Transfer	Def	Main menu	Submenu	Page
Off	Fix32	rw	SH + PRG	0	Functions	Command 3	107
On							
01/12/14.A	String	ro	%	99/08/10	Indications	Device Data	110
53BDM4340510	String	ro	%		Indications	Device Data	110
53.18	Fix32	ro	%	52.06	Indications	Device Data	110
Enabled	Fix32	rw		0	Without		135
Disabled							
0.0 to 8.0 $I_e$	Fix32	ro	%		Indications	Display	114
Espagnol	Fix32	rw	SH + PRG/dis	49	Basic	Misc	78
Italiano							
English							
Deutsch							
No stalling	Fix32	ro	%		Indications	Status 2	111
Terminals	Fix32	rw	SH + PRG	0	Basic	Control	77
Terminal/KEY							77
Term./Para							
KEY/Option							

Parameter name on display	PNU	Short description of parameter	Permissible values/meaning
StartMonitor	673	(from software version PNU 99 = 53.12) Activate waiting time function before the next start	0 = Off 1 = active
StartPause	672	(from software version PNU 99 = 53.12) waiting time status before the next start	0 = no 1 = wait
Stop-Ramp	607	Stop ramp function active	0 = Soft starter not in stop ramp mode 1 = Soft starter in Stop Ramp
Current limit [CurrentLim.2]	628 [2628]	Current limit reaction	0 = Continue ramp 1 = Disable with fault
t-Dwell [t-Dwell 2]	15 [2015]	Dwell	1 to 255 s
t-Dwell off	604	Dwell	0 = Dwell time since Top of Ramp incomplete 1 = Dwell time since Top of Ramp completed; drive can perform p. f. optimization.
Temp.Limit	44	Temperature limit	20 to 255
Thermis.LIM	626	Thermistor status	0 = Off 1 = A thermistor message has been sent.
Thermistor [Thermistor 2]	632 [2632]	Thermistor reaction	0 = Off 1 = Disable with fault
ThermistorVal	42	Thermistor actual value	0 to 255
t-Imax [t-Imax 2]	31 [2031]	Current limit time	5 to 255 s

Value selection on display	Data type	Access rights	Transfer	Def	Main menu	Submenu	Page
Off	Fix32	rw	SH + PRG	1	Monitoring	Heatsink	125
active							
No	Fix32	ro	%		Indications	Status 2	112
Wait							
No	Fix32	ro	%		Indications	Status 1	111
active							
Continue	Fix32	rw	SH + PRG	1	Functions	Command 1	97
Shutdown						Current limits	97
1 to 255 s	Fix32	rw	SH + PRG	5 s	Functions	cos-phi	100
No	Fix32	ro	%		Indications	Status 1	111
Yes							
20 to 255	Fix32	rw	Online	250	Monitoring	Heatsink	125
No	Fix32	ro	%		Indications	Status 4	112
Too hot						Monitoring	Thermistor
Continue	Fix32	rw	SH + PRG	0	Functions	Command 1	126
Shutdown						Monitoring	Thermistor
0 to 255	Fix32	ro	%		Indications	Display	113
					Monitoring	Thermistor	113
5 to 255 s	Fix32	rw	Online	30 s	Functions	Current limits	97

Parameter name on display	PNU	Short description of parameter	Permissible values/meaning
t-Imin [t-Imin 2]	29 [2029]	Undercurrent time	5 to 255 half waves
t-Kick [t-Kick 2]	14 [2014]	Kickstart time	10 to 40
T-Heatsink	37	Heatsink temperature	0 to 255
Tmp t-Stop=0	640	Auto jog	0 = Off 1 = Overwrite soft stop
Top of Ramp	603	Top of Ramp	0 = Soft starter working in ramp function or is in Stop 1 Top of ramp reached; 100 % output voltage
t-Pause	116	(from software version PNU 99 = 53.12) Waiting time before next start	0 to 3825 s, adjustable in 15 s steps
Trip-Sens.	72	Trip sensitivity	1 to 15

Value selection on display	Data type	Access rights	Transfer	Def	Main menu	Submenu	Page
5 to 255 cyc	Fix32	rw	Online	50 half waves	Functions	Current limits	97
10 to 40 cyc	Fix32	rw	SH + PRG	25 half waves	Functions	Kickstart	96
0 to 255	Fix32	ro	%		Indications	Display	113
					Monitoring	Heatsink	113
Off	Fix32	rw	SH + PRG	0	Functions	StartData	92
On						Command 2	92
No	Fix32	ro	%		Indications	Status 1	110
reached							
0 to 3825 s	Fix32	rw	SH + PRG	0	Monitoring	Heatsink	125
1 to 15	Fix32	rw	SH + PRG	1	Error		131

Parameter name on display	PNU	Short description of parameter	Permissible values/meaning
t-Start [t-Start 2]	12 [2012]	Start time	1 to 255 s
t-Start = 0 [t-Start = 0 2]	671 [2671]	(from software version PNU 99 = 53.12) Ignore start time and work with zero value (temporary)	0 = Off 1 = active
t-Stop [t-Stop 2]	17 [2017]	Stop time	0 to 255 s
t-Overload [t-Overload 2]	35 [2035]	Overload delay	10 to 140
t-Overcurr. [t-Overcurr2]	33 [2033]	Overcurrent time	5 to 255 half waves
Overload [Overload 2]	629 [2629]	Overload reaction	0 = Off 1 = Disable with fault
Overload max [OverloadMax2]	34 [2034]	Overload limit	0.6 to 2.0 $I_e$
Overload>0	609	Overload reaction	0 = Overload function on zero 1 = Overload function was initiated
Overload-Sum	36	Overload integrator	0 to 100 %
OverCurr.LIM	624	Overcurrent limit reached	0 = Off 1 Overcurrent reached and still flowing
OverCurrent [OverCurrent 2]	630 [2630]	OverCurrent	0 = Off 1 = Disable with fault
OverCurr.max [OverCurr-Max2]	32 [2032]	Overcurrent limit	1.0 to 5.0 $I_e$
U-Kick [U-Kick 2]	13 [2013]	Kickstart voltage	60 to 90 %

Value selection on display	Data type	Access rights	Transfer	Def	Main menu	Submenu	Page
1 to 255 s	Fix32	rw	SH + PRG	5 s	Basic		92
					Functions	StartData	92
Off	Fix32	rw	SH + PRG	0	Functions	Command 2	106
active							
0 to 255 s	Fix32	rw	SH + PRG	0 s	Basic		92
					Functions	StartData	92
10 to 140	Fix32	rw	Online	140	Monitoring	Motorprotect	128
5 to 255 cyc	Fix32	rw	Online	100 half waves	Monitoring	Motorprotect	128
Continue	Fix32	rw	SH + PRG	1	Functions	Command 1	128
Shutdown					Monitoring	Motorprotect	128
0.6 to 2.0 $I_e$	Fix32	rw	SH + PRG	1.09 $I_e$	Monitoring	Motorprotect	128
No	Fix32	ro	%		Indications	Status 2	111
Yes							
0 to 100 %	Fix32	ro	%		Indications	Display	113
					Monitoring	Motorprotect	128
No	Fix32	ro	%		Indications	Status 4	112
reached							
Continue	Fix32	rw	SH + PRG	1	Functions	Command 1	128
Shutdown					Monitoring	Motorprotect	128
1.0 to 5.0 $I_e$	Fix32	rw	SH + PRG	3.12 $I_e$	Monitoring	Motorprotect	128
60 to 90 %	Fix32	rw	SH + PRG	75 %	Functions	Kickstart	96



Parameter name on display	PNU	Short description of parameter	Permissible values/meaning
Umax	110	Umax	0 to 50
Umax reached	605	Max. output voltage reached	0 = Thyristors working with phase control 1 = thyristors working at maximum delay angle
UnderCurr.LIM	625	UnderCurrent	0 = Off 1 = Undercurrent occurred and still flowing
UnderCurrent [Undercurr.2]	631 [2631]	Undercurrent reaction	0 = Off 1 = Disable with fault
UserParametr	111	User parameter	0 to 255
U-Start [U-Start 2]	11 [2011]	Start pedestal	10 to 60 %
U-Stop [U-Stop 2]	16 [2016]	Stop pedestal	10 to 60 %
U-Stopramp [U-Stopramp2]	634 [2634]	Stop ramp control	0 = Off 1 = Run stop ramp voltage-referenced
Full Load	611	Full load operation	0 = p. f. optimization can be activated. 1 = Due to high load, p. f. optimization cannot be activated, even if selected.
Delay angle	22	Delay angle	0 to 146°

Value selection on display	Data type	Access rights	Transfer	Def	Main menu	Submenu	Page
0 to 50	Fix32	rw	Online	10	Functions	Open-loop phase control	108
No	Fix32	ro	%		Indications	Status 1	111
Yes							
No	Fix32	ro	%		Indications	Status 4	112
reached							
Continue	Fix32	rw	SH + PRG	0	Functions	Command 1	97
Shutdown							
0 to 255	Fix32	rw	Online	0	Functions	Open-loop phase control	108
10 to 60 %	Fix32	rw	SH + PRG	20 %	Basic	StartData	92
10 to 60 %							
10 to 60 %	Fix32	rw	SH + PRG	10 %	Functions	StartData	92
Off							
On	Fix32	rw	SH + PRG	0	Functions	StartData	92
Off							
On	Fix32	ro	%		Indications	Status 2	111
reached							
0 to 146°	Fix32	ro	%		Indications	Display	113



## External add-on components

### Contactor and motor protection devices

Notes about the tables below:

#### DM4-340-...

With different operating cycles, the r.m.s. current value changes, so that higher rated components may have to be used. The switching and protective elements were selected for the following operating cycle (no bypass used for any operating cycle):

- Devices DM4-340-7K5 to DM4-340-90K  
per 10 operations per hour, continuous operation.
- Devices DM4-340-110K and DM4-340-132  
per 10 operations per hour with zero-current break of at least 3 minutes before the next start.
- Devices from DM4-340-160K  
per 3 operations per hour with zero-current break of at least 8 minutes before the next start.

For other operating cycles or where a bypass is used, the effective rating – and therefore the required device – change. The rated operational current (DM4) must be greater than the motor current stated on the motor's nameplate (in-line operation) or motor current/ $\sqrt{3}$  (in-delta operation).

#### Rated operational current

Related to the specified load cycle.

#### Rated operational current of cable

Related to the specified load cycle.

#### *I* (cable)

Indicates the current for which the supply cable must be dimensioned at the specified operating cycle and motor current. At higher motor currents and for other operating cycles (operating frequency, overcurrent, overcurrent time, duty factor), this value changes and must be adapted accordingly.

**Mains contactor**

If the control circuit ensures that the controller is disabled before the mains contactor switches off, the contactors in column "Bypass contactor" can also be used as mains contactors.

**Overload relay**

If the soft starter is continuously live, it can act as a motor overload relay.

In in-delta operation, the overload relay is connected in series with the motor winding and set to the value motor current/  $\sqrt{3}$ .

**ZMM...**

Setting the ZMM trip block to  $t_r = \infty$  (OBI)

**IZM...**

To use an IZM as "contactor", additional equipment is required – see IZM catalogue. In this case, the suggested circuits apply only to a limited extent, since different contacts must be connected, depending on the selected accessories.

Soft starters for three-phase mains connection, short startup time, tripping class 10 (15 s,  $3.5 \times I_e$ )

DM4-340-...	Motor rating at 400 V [kW]	Rated operational current			Motor/cable protection	
		(DM4) [A]	(motor) $I_e$ [A]	(cable) $I$ [A]	Line protection	Mains contactor (optional)

#### In-line connection (before load, standard)

..-7K5	7.5	16	15.2	16	PKM0-16(+CL-PKZ0)	DIL0M
..-11K	11	23	21.7	23	PKM0-25(+CL-PKZ0)	DIL0AM
..-15K	15	30	29.3	30	PKZ2 + M-32-PKZ2 (+CL-PKZ2)	DIL1M
..-22K	22	44	41	44	NZM7-63N-OBI	DIL2M
..-30K	30	59	55	59	NZM7-63N-OBI	DIL2AM
..-37K	37	72	68	72	NZM7-80N-OBI	DIL3M80
..-45K	45	85	81	85	NZM7-100N-OBI	DIL3AM85
..-55K	55	105	99	105	NZM7-125N-OBI	DIL4M115
..-75K	75	146	134	146	NZM7-160N-OBI	DIL4AM145
..-90K	90	174	161	174	NZM7-200N-OBI	DILM185
..-110K	110	202	196	202	NZM7-200N-OBI	DILM225
..-132K	132	242	231	242	NZM10-400S/ZMM400	DILM250
..-160K	160	300	279	300	NZM10-400S/ZMM400	DILM300
..-200K	200	370	349	370	NZM10-400S/ZMM400	DILM400
..-250K	250	500	437	500	NZM10-630S/ZMM-630	DILM500
..-315K	315	600	544	600	NZM10-630S/ZMM-630	DILM580
..-400K	400	750	683	750	NZM14-800S	DILM750
..-500K	500	900	860	900	IZMB1-U1000	

Overload relay	Bypass contactor (optional)	Circuit-breaker controller supply	Semiconductor fuse (optional, required fuse for type "2" coordination)	
			Fuses Quantity × type	Fuse holders Quantity × type

Z00-16(+EZ00)	DIL00M	PKZM0-0,16	3 × 20.282.20-40	3 × 21.189.01
Z00-24(+EZ00)	DIL0M		3 × 20.282.20-80	3 × 21.189.01
Z1-40(+EZ1)	DIL0M		3 × 20.282.20-80	3 × 21.189.01
Z1-57(+EZ1)	DIL1M		3 × 20.282.20-125	3 × 21.189.01
Z1-63(+EZ1)	DIL2M		3 × 20.282.20-125	3 × 21.189.01
Z5-100/SK3	DIL2M		3 × 20.189.20-200	3 × 21.189.01
Z5-100/SK3	DIL2M		3 × 20.189.20-200	3 × 21.189.01
Z5-125/SK4	DIL3M80		3 × 20.610.32-350	3 × 21.313.02
Z5-150/SK4	DIL4M115		3 × 20.610.32-350	3 × 21.313.02
Z5-220/FF6	DILM185		3 × 20.610.32-450	3 × 21.313.02
Z5-220/FF6	DILM185		3 × 20.610.32-450	3 × 21.313.02
ZW7-290	DILM225		3 × 20.610.32-500	3 × 21.313.02
ZW7-400	DILM250		3 × 20.610.32-500	3 × 21.313.02
ZW7-400	DILM300		3 × 20.610.32-630	3 × 21.313.02
ZW7-540	DILM400	PKZM0-1,6	3 × 20.630.32-900	3 × 21.313.02
ZW7-630	DILM500		3 × 20.630.32-900	3 × 21.313.02
ZW7-820	DILM650		3 × 20.630.32-1250	3 × 21.313.02
–	IZMB1-U1000		3 × 20.630.32-1250	3 × 21.313.02



Soft starters for three-phase mains connection, short startup time, tripping class 10 (15 s,  $3.5 \times I_e$ )

DM4-340-...	Motor rating at 400 V [kW]	Rated operational current			Motor/cable protection	
		(DM4) [A]	(motor) $I_e$ [A]	(cable) $I$ [A]	Line protection	Mains contactor (optional)

**In-delta connection (in series with each motor winding)**

..-7K5	11	16	21.7	21.7	PKM0-25(+CL-PKZ0)	DIL0AM
..-11K	15	23	29.3	29.3	PKZ2+M-32-PKZ2 (+CL-PKZ2)	DIL1M
..-15K	22	30	41	41	NZM7-63N-OBI	DIL2M
..-22K	30	44	55	55	NZM7-63N-OBI	DIL2AM
	37		68	68	NZM7-80N-OBI	DIL3M80
..-30K	45	59	81	81	NZM7-100N-OBI	DIL3AM85
	55		99	99	NZM7-125N-OBI	DIL4M115
..-45K	75	85	134	134	NZM7-160N-OBI	DIL4AM145
..-55K	90	105	161	161	NZM7-200N-OBI	DILM185
..-75K	110	146	196	196	NZM7-200N-OBI	DILM225
	132		231	231	NZM10-400S/ZMM400	DILM250
..-90K	160	174	279	279	NZM10-400S/ZMM400	DILM300
..-132K	200	242	349	349	NZM10-400S/ZMM400	DILM400
..-160K	250	300	437	437	NZM10-630S/ZMM-630	DILM500
..-200K	315	370	544	544	NZM10-630S/ZMM-630	DILM580
..-250K	400	500	683	683	NZM14-800S	DILM750
..-315K	500	600	860	860	IZMB1-U1000	
	560		960	960	IZMB1-U1250	
..-400K	750	750	1280	1280	IZMB1-U1600	
..-500K	900	900	1540	1540	IZMB2-U2000	

Overload relay	Bypass contactor (optional)	Circuit-breaker controller supply	Semiconductor fuse (optional, required fuse for type "2" coordination)	
			Fuses Quantity × type	Fuse holders Quantity × type

Z00-16+EZ00	DIL00M	PKZM0-0,16	3 × 20.282.20-40	3 × 21.189.01
Z00-24+EZ00	DIL0M		3 × 20.282.20-80	3 × 21.189.01
Z1-40+EZ1	DIL0M		3 × 20.282.20-80	3 × 21.189.01
Z1-57+EZ1	DIL1M		3 × 20.282.20-125	3 × 21.189.01
Z1-57+EZ1				
Z1-63+EZ1	DIL2M		3 × 20.282.20-125	3 × 21.189.01
Z1-63+EZ1				
Z5-100/KK4	DIL2M		3 × 20.189.20-200	3 × 21.189.01
Z5-125/KK4	DIL4M115		3 × 20.610.32-350	3 × 21.313.02
Z5-150/KK4	DIL4M115		3 × 20.610.32-350	3 × 21.313.02
Z5-150/KK4				
Z5-220/FF6	DILM185		3 × 20.610.32-450	3 × 21.313.02
ZW7-290	DILM225		3 × 20.610.32-500	3 × 21.313.02
ZW7-400	DILM250	3 × 20.610.32-500	3 × 21.313.02	
ZW7-400	DILM400	3 × 20.610.32-630	3 × 21.313.02	
ZW7-540	DILM500	PKZM0-1,6	3 × 20.630.32-900	3 × 21.313.02
ZW7-630	DILM580		3 × 20.630.32-900	3 × 21.313.02
ZW7-630				
ZW7-820	DILM750		3 × 20.630.32-1250	3 × 21.313.02
–	IZMB1-U1000		3 × 20.630.32-1250	3 × 21.313.02

Soft starters for three-phase mains connection, long start-up time, tripping class 20 (40 s,  $3.5 \times I_e$ )

DM4-340-...	Motor rating at 400 V [kW]	Rated operational current			Motor/cable protection	
		(DM4) [A]	(motor) $I_e$ [A]	(cable) $I$ [A]	Line protection	Mains contactor (optional)
<b>In-line connection (before load, standard)</b>						
..-11K	7.5	16	15.2	21	PKM0-25(+CL-PKZ0)	DIL0M
..-15K	11	22	21.7	31	PKZ2+M-32-PKZ2 (+CL-PKZ2)	DIL0AM
..-22K	15	30	29.3	41	NZM7-63N-OBI	DIL1M
..-30K	22	44	41	58	NZM7-63N-OBI	DIL2M
..-37K	30	55	55	78	NZM7-80N-OBI	DIL2AM
..-45K	37	72	68	96	NZM7-100N-OBI	DIL3M80
..-55K	45	85	81	114	NZM7-160N-OBI	DIL4M115
..-75K	55	105	99	140	NZM7-160N-OBI	DIL4M115
..-90K	75	140	134	189	NZM7-200N-OBI	DILM185
..-110K	90	170	161	227	NZM7-250N-OBI	DILM225
..-132K	110	200	196	276	NZM10-400S/ZMM400	DILM250
..-160K	132	240	231	326	NZM10-400S/ZMM400	DILM300
..-200K	160	280	279	393	NZM10-400S/ZMM400	DILM400
..-250K	200	350	349	492	NZM10-630S/ZMM-630	DILM500
..-315K	250	450	437	616	NZM10-630S/ZMM-630	DILM580
..-400K	315	550	544	767	NZM14-800S	DILM750
..-500K	400	700	683	963	IZMB1-U1000	

Overload relays	Bypass contactor (optional)	Circuit-breaker controller supply	Semiconductor fuse (optional, required fuse for type "2" coordination)	
			Fuses Quantity × type	Fuse holders Quantity × type
ZEV+ZEV-XSW-25	DIL00M	PKZM0-0,16	3 × 20.282.20-80	3 × 21.189.01
ZEV+ZEV-XSW-25	DIL0M		3 × 20.282.20-80	3 × 21.189.01
ZEV+ZEV-XSW-65	DIL0M		3 × 20.282.20-125	3 × 21.189.01
ZEV+ZEV-XSW-65	DIL1M		3 × 20.282.20-125	3 × 21.189.01
ZEV+ZEV-XSW-65	DIL2M		3 × 20.189.20-200	3 × 21.189.01
ZEV+ZEV-XSW-145	DIL2M		3 × 20.189.20-200	3 × 21.189.01
ZEV+ZEV-XSW-145	DIL2M		3 × 20.610.32-350	3 × 21.313.02
ZEV+ZEV-XSW-145	DIL3M80		3 × 20.610.32-350	3 × 21.313.02
ZEV+ZEV-XSW-145	DIL4M115		3 × 20.610.32-450	3 × 21.313.02
ZEV+ZEV-XSW-820	DILM185		3 × 20.610.32-450	3 × 21.313.02
ZEV+ZEV-XSW-820	DILM185	PKZM0-1,6	3 × 20.610.32-500	3 × 21.313.02
ZEV+ZEV-XSW-820	DILM225		3 × 20.610.32-500	3 × 21.313.02
ZEV+ZEV-XSW-820	DILM250		3 × 20.610.32-630	3 × 21.313.02
ZEV+ZEV-XSW-820	DILM300		3 × 20.630.32-900	3 × 21.313.02
ZEV+ZEV-XSW-820	DILM400		3 × 20.630.32-900	3 × 21.313.02
ZEV+ZEV-XSW-820	DILM500		3 × 20.630.32-1250	3 × 21.313.02
ZEV+ZEV-XSW-820	DILM650		3 × 20.630.32-1250	3 × 21.313.02

Soft starters for three-phase mains connection, long start-up time, tripping class 20 (40 s,  $3.5 \times I_e$ )

DM4-340-...	Motor rating at 400 V [kW]	Rated operational current			Motor/cable protection	
		(DM4) [A]	(motor) $I_e$ [A]	(cable) $I$ [A]	Line protection	Mains contactor (optional)

**In-delta connection (in series with each motor winding)**

..-7K5	11	13	21.7	31	PKZ2+M-32-PKZ2 (+CL-PKZ2)	DIL0AM
..-15K	15	22	29.3	41	NZM7-63N-OBI	DIL1M
..-22K	22	30	41	58	NZM7-63N-OBI	DIL2M
..-30K	30	44	55	78	NZM7-80N-OBI	DIL2AM
	37		68	96	NZM7-100N-OBI	DIL3M80
..-37K	45	55	81	114	NZM7-160N-OBI	DIL4M115
..-45K	55	72	99	140	NZM7-160N-OBI	DIL4M115
..-55K	75	85	134	189	NZM7-200N-OBI	DILM185
..-75K	90	105	161	227	NZM7-250N-OBI	DILM225
..-90K	110	140	196	276	NZM10-400S/ZMM400	DILM250
	132		231	326	NZM10-400S/ZMM400	DILM300
..-110K	160	170	279	393	NZM10-400S/ZMM400	DILM400
..-160K	200	240	349	492	NZM10-630S/ZMM-630	DILM500
..-200K	250	280	437	616	NZM10-630S/ZMM-630	DILM580
..-250K	315	350	544	767	NZM14-800S	DILM750
..-315K	400	450	683	963	NZM14-1000S	DILM750
..-400K	500	550	860	1213	IZMB1-U1250	
..-500K	560	700	960	1354	IZMB1-U1600	

Overload relays	Bypass contactor (optional)	Circuit-breaker controller supply	Semiconductor fuse (optional, required fuse for type "2" coordination)	
			Fuses Quantity × type	Fuse holders Quantity × type

ZEV+ZEV-XSW-25	DIL0M	PKZM0-0,16	3 × 20.282.20-40	3 × 21.189.01
ZEV+ZEV-XSW-65	DIL0M		3 × 20.282.20-80	3 × 21.189.01
ZEV+ZEV-XSW-65	DIL1M		3 × 20.282.20-125	3 × 21.189.01
ZEV+ZEV-XSW-65	DIL2M		3 × 20.282.20-125	3 × 21.189.01
ZEV+ZEV-XSW-145	DIL2M			
ZEV+ZEV-XSW-145	DIL2M		3 × 20.189.20-200	3 × 21.189.01
ZEV+ZEV-XSW-145	DIL3M80		3 × 20.189.20-200	3 × 21.189.01
ZEV+ZEV-XSW-145	DIL4M115		3 × 20.610.32-350	3 × 21.313.02
ZEV+ZEV-XSW-820	DILM185		3 × 20.610.32-350	3 × 21.313.02
ZEV+ZEV-XSW-820	DILM185		3 × 20.610.32-450	3 × 21.313.02
ZEV+ZEV-XSW-820	DILM225			
ZEV+ZEV-XSW-820	DILM250		3 × 20.610.32-450	3 × 21.313.02
ZEV+ZEV-XSW-820	DILM300		3 × 20.610.32-500	3 × 21.313.02
ZEV+ZEV-XSW-820	DILM400		3 × 20.610.32-630	3 × 21.313.02
ZEV+ZEV-XSW-820	DILM500	PKZM0-1,6	3 × 20.630.32-900	3 × 21.313.02
ZEV+ZEV-XSW-820	DILM650		3 × 20.630.32-900	3 × 21.313.02
ZEV+ZEV-XSW-821	IZMB1-U1000		3 × 20.630.32-1250	3 × 21.313.02
ZEV+ZEV-XSW-822	IZMB1-U1000		3 × 20.630.32-1250	3 × 21.313.02

**Dimensions**



During assembly, please consider the weight and dimensions of the soft starter. Use appropriate handling and lifting equipment (lifting trolley and/or crane for larger weights) and tools. Improper handling and the use of incorrect tools can damage the soft starter.

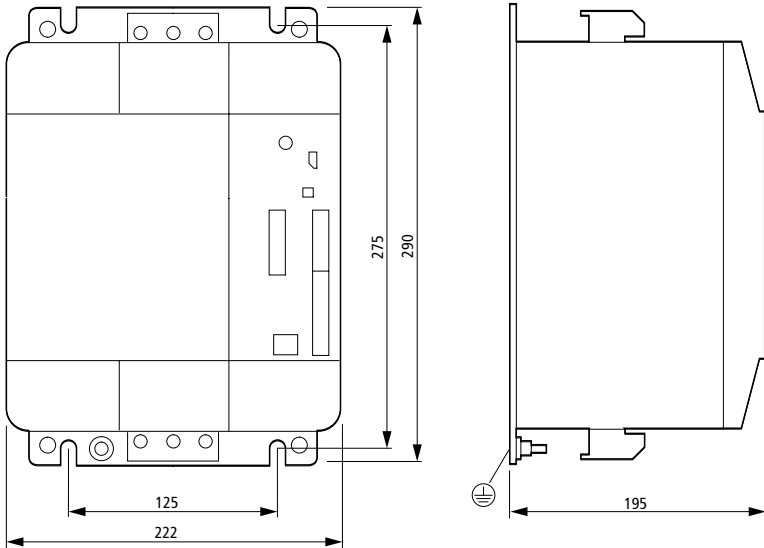

Figure 59: Dimensions for DM4-340-7K5 to DM4-340-37K

DM4-340-...	Ø	kg
...-7K5	M6	6.7
...-11K		
...-15K		
...-22K		
...-30K		
...-37K		

**Dimensions**

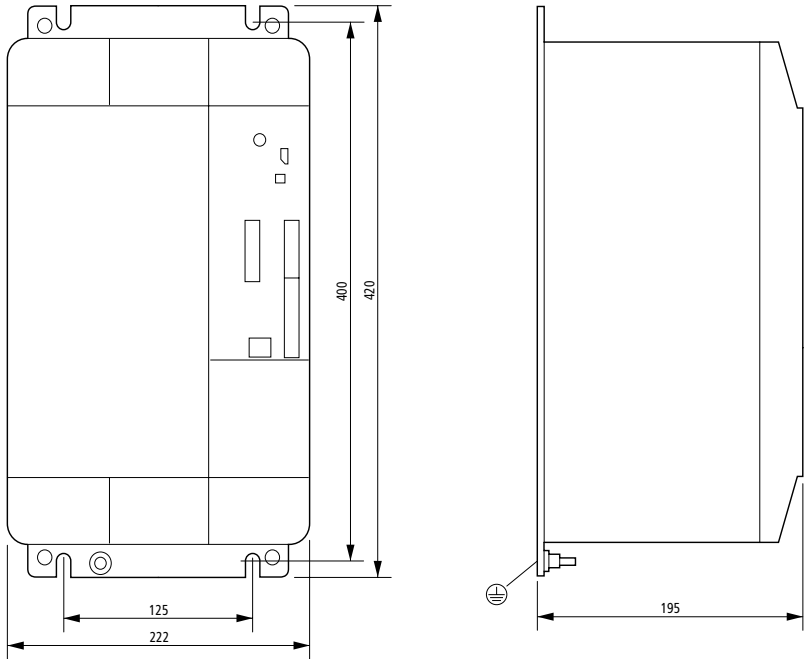

Figure 60: Dimensions for DM4-340-45K to DM4-340-75K

DM4-340-...	Ø	kg
...-45K	M6	15
...-55K		
...-75K		

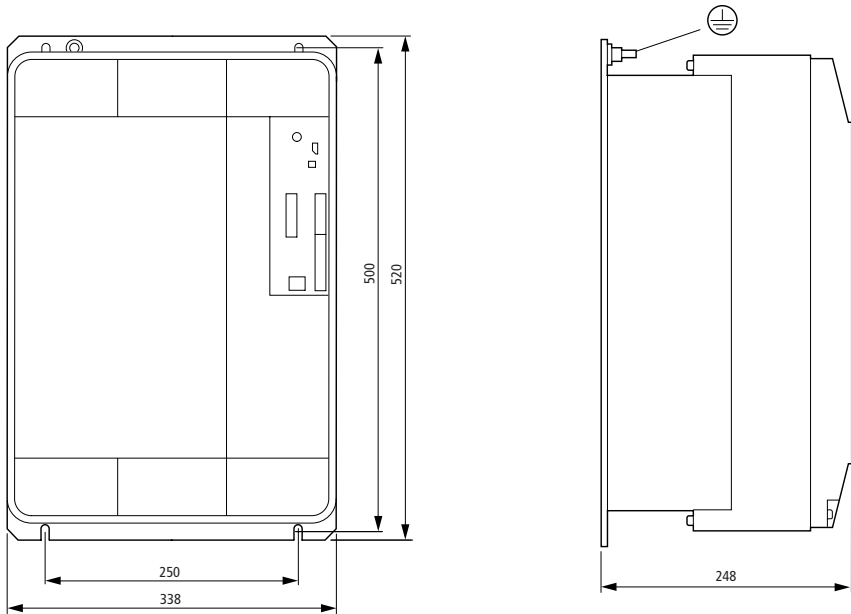

Figure 61: Dimensions for DM4-340-90K to DM4-340-200K

DM4-340-...	Ø	kg
...-90K	M6	15.7
...-110K		
...-132K		22
...-160K		
...-200K		

Dimensions

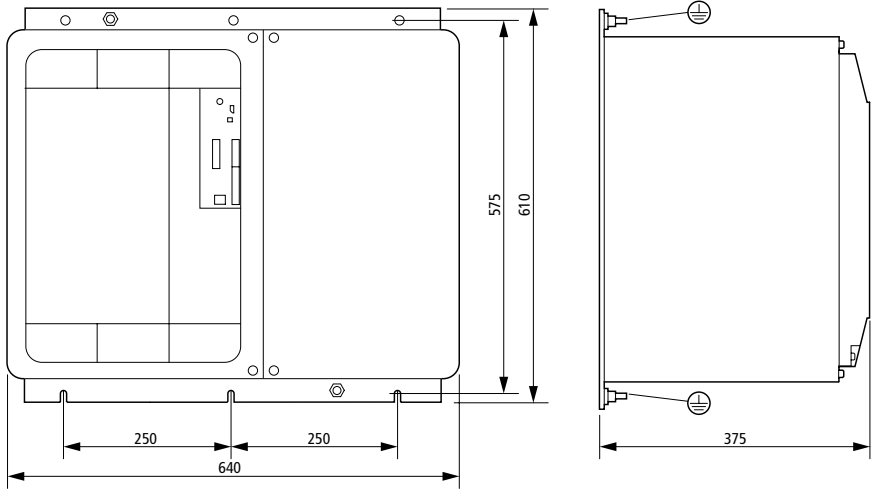

Figure 62: Dimensions for DM4-340-250K to DM4-340-500K

DM4-340-...	Ø	kg
...-250K	M10	65
...-315K		
...-400K		72
...-500K		



## Index

<b>A</b>	Accessories .....	228
	Ambient temperature .....	172, 182
	Analog	
	In (submenu) .....	104
	Inputs .....	190
	Inputs, 0 to 10 V DC, 4 to 20 mA .....	104
	Out (submenu) .....	114
	Out 1 .....	114
	Outputs .....	67, 113, 115, 190
	Signals .....	146
	Analog setpoint values .....	66
	Angle of inclination .....	141
	App. switch	
	active .....	77
	inactive .....	77
	Application selector switch .....	71
<b>B</b>	Basic .....	76
	Baud rate .....	90
	Belt drives .....	93
	Bit16 .....	195
	Blocking protection .....	128
	Break contact .....	118
	Breakaway torque .....	94, 96
	Bypass connection .....	40

<b>C</b>	Cable cross-sections .....	145, 174, 184
	Cables .....	27
	Circuit configurations .....	29
	Class 15 .....	117
	Command (submenu) .....	105
	Communication behaviour .....	91
	Configuration .....	79
	Connectable motor rating .....	10
	Connecting a PLC .....	64
	Connecting motors .....	10
	Connecting the control signal cables .....	145
	Connections .....	143
	Contact protection .....	172, 182
	Contactors .....	27
	Contaminated cooling air .....	138
	Contaminated filters .....	138
	Control (submenu) .....	79
	Control angle .....	108
	Control circuit .....	176, 186
	Controller inhibit .....	72, 91
	Controller supply voltage .....	59
	Conversion of overload withstand capability .....	193
	Conveyor belts .....	93
	Coordination type .....	24
	Corrosive gases .....	138
	cos-phi optimization (submenu) .....	100
	Current (submenu) .....	96
	Current limit .....	97, 148
	Current limit reaction .....	13
	Current signal .....	67

<b>D</b>	Dahlander .....	28
	Data transfer .....	195
	DE4-KEY-2 .....	71
	Default factory setting .....	75, 85
	Degree of pollution .....	172, 182
	Delay angle .....	67
	Delay time .....	118
	Delays .....	119
	Device address .....	90
	Device Data (submenu) .....	110
	Diagnostics .....	117
	Digital inputs .....	64, 103, 190
	Digital-In (submenu) .....	103
	Dimensions .....	172, 182, 236
	Display (submenu) .....	113
	Drive belt breakage .....	99
	Duty factor .....	192
<b>E</b>	EMC Directive .....	15, 108
	Emergency operation .....	44
	Enable .....	31
	Environmental influences .....	14
	External auxiliary components .....	228
<b>F</b>	Fault messages .....	117, 131, 154, 156, 157
	Fault reset .....	155
	Fix32 .....	195
	Free-wheeling diode .....	69
<b>H</b>	Heatsink (submenu) .....	125
	Heavy starting duty .....	118

<b>I</b>	<i>I</i> <sub>2t</sub> value .....	118, 129
	Idling .....	99
	Immediate stop .....	31
	Impacts .....	140
	In-delta connection .....	12, 48
	Induction motors .....	28
	Initial display parameter .....	91
	Inputs .....	66, 176, 186
	Installation clearance .....	139
	Installation height .....	172, 182
	Int16 .....	195
	Interface modules .....	71
	Interference immunity .....	64, 69
	Internal voltages .....	61
<hr/>		
<b>K</b>	Kickstart (submenu) .....	96
<hr/>		
<b>L</b>	Language selection .....	90
	LCD keypad .....	9, 71, 72, 117
	LED displays .....	155
	LEDs .....	132
	Load .....	10
	Long motor cables .....	30
	Low Voltage Directive .....	15
<hr/>		
<b>M</b>	Machinery Safety Directive .....	15
	Mains contactor .....	119
	Mains filters .....	27
	Mains frequency .....	170, 180
	Make contact .....	68, 118
	Measuring instruments .....	67
	Menu structure .....	160
	Misc (submenu) .....	90
	Monitor signal .....	67
	Monitoring signals .....	156

Motor	
Cascade .....	54
Connect .....	10
Connecting the cable .....	144
Does not start .....	153
Excessive current consumption .....	154
Full load current .....	10
Full protection .....	30
Rating .....	170, 180
Running unevenly .....	153
Screening cables .....	145
Starting .....	149
Stops immediately after start .....	153
Temperature .....	126
Torque .....	29
Motor protection	
Function .....	117, 129
Relay .....	32
Switch .....	32
Motorprotect	
(submenu) .....	128
Mounting .....	137
Mounting positions .....	141
Mounting/Installation .....	137
<hr/>	
<b>N</b>	
Networkable .....	9
Nominal device current .....	90
<hr/>	
<b>O</b>	
Operating level .....	159
Operating menu .....	159
Operation .....	149
Output voltage .....	29, 108
Overcurrent duration .....	192
Overcurrent reaction .....	192
Overcurrent shutdown .....	154
Overheating .....	98, 154
Overload relays .....	58, 117
Overload withstand capability .....	192
Overvoltages .....	32

<b>P</b>	P. f. correction systems .....	23
	Package contents .....	137
	Parallel connection .....	10, 58
	Parameter	
	Set .....	84
	Table (alphabetic) .....	198
	Parameter set .....	71
	Changeover .....	86
	Preset .....	72
	Transfer .....	86
	Parameters	
	Names .....	72
	Saving .....	72, 85
	Saving permanently .....	85
	Password .....	81
	PE terminal .....	27
	PhaseControl (submenu) .....	108
	PLC .....	63
	Plug-in screw terminals .....	143
	Potential, zero .....	62, 64
	Power dissipation .....	13, 172, 182
	Power On parameters .....	85
	Power supply .....	170, 180
	Product Standard EN 60947-4-2 .....	15
	Programmable analog outputs .....	176, 186
	Programmable relay outputs .....	176, 186
	Protection class .....	172, 182
	Protection functions .....	117
	Protective elements .....	24
	Protective elements, tripping .....	97
	Pump connection .....	44

<b>R</b>	Radio interference level B .....	36
	Radio interference suppression filter .....	108
	Ramp time .....	13, 93, 97, 148
	Rated control supply voltage .....	59
	Rated operational voltage .....	170, 180
	RC filter .....	69
	Read/write .....	77
	Ready for operation signal .....	35
	Reference input variable definition .....	67
	Reinitialization .....	91
	Relay contacts .....	68, 117
	Relay outputs .....	191
	K1 (submenu) .....	118
	K2 to K4 (submenus) .....	124
	Reset fault message/register .....	133
	Response threshold .....	131
	Reversing circuit .....	52
	Reversing contactor .....	30
	Root-3 circuit .....	48
<b>S</b>	Screening the control signal cables .....	146
	Semiconductor fuses .....	24
	Setpoint value .....	108
	Side clearance .....	139
	Signalling threshold .....	104
	Slipping motor .....	28
	Soft start functions .....	178, 188
	Soft starter configuration .....	19, 148
	Speed/torque characteristic .....	10
	Stable speed characteristics .....	101
	Standard applications .....	19
	Standard connection .....	11, 36
	Standards .....	169
	Start pedestal .....	93
	Startcommand .....	79
	StartData (submenu) .....	92
	Starting torque .....	8
	Starts per hour .....	192
	Start-up .....	147

	Status (submenu) .....	110
	Status 1 .....	110
	Status 2 .....	111, 112
	Status 3 .....	112
	Status 4 .....	112
	Status display of LCD keypad .....	168
	Structure of type code .....	7
<hr/>		
<b>T</b>	Technical data .....	170
	Terminal configuration .....	102
	Thermal memory .....	118
	Thermistor (submenu) .....	126
	Thermistor input .....	191
	Thermistors .....	58
	Torque .....	8, 94
	Trip sensitivity .....	132
	Tripping class .....	117
	Troubleshooting .....	153
<hr/>		
<b>U</b>	Unstable speed characteristics .....	101
<hr/>		
<b>V</b>	Vibration .....	140
	Voltage ramp .....	96
<hr/>		
<b>W</b>	Weight .....	172, 182